

Service Manual
Insulation Blowing Machine
novaG-fill 60
novaG-fill 60 G



Issue 1.2 18/08/22
Ref. NR-00006-ENG



Please carefully read all the technical and safety documents in the Service Manual before installing and starting up the machine. Special attention must be paid to this information in order to understand how the machine is used. Its purpose is to enhance user safety and prevent breakdowns caused by incorrect use.



GUARANTEE

HI-TECH SPRAY EQUIPMENT, S. A. (hereinafter “HI-TECH”) grants this Limited Guarantee to the original buyer (hereinafter the “Client”) for the unit and the original accessories given with the unit (hereinafter the “Product”) against any fault in the design, materials or manufacture of the Product at the time of the first purchase by the user and for a duration of two (2) years thereafter.

If during the guarantee period and under normal conditions of use, the Product should fail to work correctly due to defects of design, material or manufacture, the authorised distributor of the country where the HI-TECH Product or technical assistance service has been purchased shall repair or replace the Product in accordance with what is established in the following:

CONDITIONS

- a) The validity of this guarantee will be subject to the presentation of the original invoice issued by the HI-TECH authorised distributor for the sale of the Product along with the Product handed over for repair or replacement, which must show the date of purchase and the serial number. HI-TECH reserves the right to refuse to give the guarantee service when the indicated data fail to appear on the invoice or have been modified after the purchase of the Product.
- b) The repaired or replaced Product will continue to maintain the original guarantee for the time remaining until the end of the guarantee or for three (3) months from the repair date, if the remaining period of the original guarantee were shorter.
- c) This guarantee will not be applied to the faults in the Product caused by its faulty installation, the natural wear and tear of the components, any use other than that considered normal for this Product or which should fail to strictly comply with the instructions of use provided by HI-TECH; due to accident, carelessness, adjustments, alterations or modifications of the Product not authorised by HI-TECH or due to the use of accessories, heating devices, pumping equipment and/or dispensers that have not been approved or manufactured by HI-TECH.
- d) The guarantee applicable to the components and accessories forming part of the Product and which have not been made by HI-TECH will be limited to the guarantee offered by the original manufacturer thereof.

HI-TECH WILL NOT RECOGNISE ANY EXPRESS ORAL OR WRITTEN GUARANTEES OTHER THAN THIS PRINTED LIMITED GUARANTEE. ALL IMPLICIT GUARANTEES, INCLUDING, WITHOUT LIMIT, ADAPTATION FOR A SPECIFIC USE, ARE SUBJECT TO THE DURATION OF THIS WRITTEN GUARANTEE. HI-TECH DOES NOT ASSUME ANY KIND OF COMMITMENT OR RESPONSIBILITY FOR ALL POSSIBLE DAMAGE OR EXPENSE CAUSED BY FAULTS IN THE OUTPUT OF THE PRODUCT, ITS WORKING OR THE DISPENSING OF MATERIAL THROUGH THE PRODUCT, INCLUDING, WITHOUT LIMITATION, ALL EXPENSES CAUSED BY DAMAGE TO PEOPLE OR PROPERTY. EQUALLY, HI-TECH WILL IN NO CASE ACCEPT LIABILITY FOR THE LOSS OF SPECULATIVE PROFITS OR COMMERCIAL LOSSES. ALL REPAIRS OR REPLACEMENT OF FAULTY PRODUCTS WILL CONSTITUTE THE COMPREHENSIVE FULFILMENT OF HI-TECH'S OBLIGATIONS WITH RESPECT TO THE CLIENT. HI-TECH DOES NOT IN ANY WAY GUARANTEE THE SUITABILITY OR APTITUDE OF ITS PRODUCT FOR ANY PARTICULAR PURPOSE OR APPLICATION.

All information provided on components which have not been manufactured by HI-TECH and which is based on reports received from the original manufacturer, though considered precise and reliable, is provided without any guarantee or responsibility of any explicit or implicit kind.

All concession, sale or financial leasing of the Product by HI-TECH in no case explicitly or implicitly constitutes any authorisation, acceptance or concession for the use of any rights or patents, nor does it encourage, nurture or back their infringement.

The restrictions on the guarantee suppose no limitation on the legal rights of the consumer established in applicable national legislation, nor do they affect any rights derived from the bargain and sale agreement between the consumer and supplier.

All information provided in this manual has been included in the confidence that it is true, although it does not constitute any responsibility or implicit or explicit guarantee. HI-TECH reserves the right at any time and without prior warning to make all improvements and modifications necessary to this manual, in order to rectify any possible typographical errors, increase the information contained or insert the changes caused to the characteristics and performance of the unit.



SAFETY AND HANDLING

The equipment described in this manual has been designed and manufactured in compliance with the following European Directives, following as application guide the harmonized standards detailed and in conformity with the relevant UK Statutory Instruments (and their amendments):

Directive 2006/42/EC on machinery (UK Supply of Machinery (Safety) Regulations 2008)

UNE EN 12100:2012 (BS EN ISO 12100:2010)

Directive 2014/30/EU on electromagnetic compatibility (UK Electromagnetic Compatibility Regulations 2016)

UNE EN 55011 (BS UNE EN 55011)

UNE EN 55016-2-1 (BS UNE EN 55016-2-1); UNE EN 55016-2-3 (BS UNE EN 55016-2-3);
UNE EN 55032 (BS UNE EN 55032)

UNE EN 61000-3-2 (BS UNE EN 61000-3-2); UNE EN 61000-3-3 (BS UNE EN 61000-3-3);
UNE EN 61000-4-2 (BS UNE EN 61000-4-2); UNE EN 61000-4-3 (BS UNE EN 61000-4-3);
UNE EN 61000-4-4 (BS UNE EN 61000-4-4); UNE EN 61000-4-5 (BS UNE EN 61000-4-5);
UNE EN 6100-4-6 (BS UNE EN 6100-4-6); UNE EN 61000-4-8 (BS UNE EN 61000-4-8); UNE
EN 61000-4-11 (BS UNE EN 61000-4-11)

Directive 2014/68/EU on pressure equipment (UK Pressure Equipment (Safety) Regulations 2016)

UNE EN 809:1999 +A1 (BS EN 809:1998 +A1:2009)

Directive 2014/35/EU on electrical safety (UK Electrical Equipment (Safety) Regulations 2016)

UNE EN 60204-1:2019 (BS EN 60204-1:2018)

Directive 2003/10/EC on noise level (UK The Control of Noise at Work Regulations 2005)

UNE EN ISO 3740 (BS EN ISO 3740:2019)

UNE EN ISO 3746 (BS EN ISO 3746:2010)

Directive 2011/65/EU on the restriction of the use of certain hazardous substances in electrical and electronic equipment with amendment 2015/863/EU (UK The Restriction of the Use of Certain Hazardous Substances in Electrical and Electronic Equipment Regulations 2012)

Directive 2012/19/EU on waste electrical and electronic equipment (UK The Waste Electrical and Electronic Equipment Regulations 2013)

Regulation (EU) 2016/1628 on engine emissions, Phase V



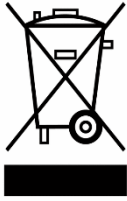

Electrical products cannot be thrown out with the rubbish. They must be taken to a dedicated collection point for an environmentally sound disposal in accordance with local regulations. You must contact your local collective or retailer for information about recycling. Before leaving WEEE at appropriate collection facilities, batteries must be removed and disposed of separately for proper recycling. The packaging materials are recyclable. Dispose of packaging materials in an environmentally sound manner and place them at the disposal of recycling

sectors.

TRANSPORT AND STORAGE

Proper precautions must be taken so that the equipment can withstand the effects of transport and storage temperatures between -25°C and $+55^{\circ}\text{C}$ or up to $+70^{\circ}\text{C}$ for short periods that do not exceed 24 hours. Also, appropriate means to prevent damage from moisture, vibrations or shocks must be foreseen.

The model **novaG-fill 60** and **novaG-fill 60-G** insulation blowing machines have been designed and manufactured in compliance with the 2006/42/EEC Machinery Directive and the National Regulations implementing it. It also complies with the applicable European Electromagnetic Compatibility and Electric Safety Directives and Harmonised Standards.

This section contains important information on the safety, handling and use of the model **novaG-fill 60** and model **novaG-fill 60 G** insulation blowing machines.



Please carefully read all the technical and safety documents included in the Service Manual before installing and starting up the machine. It is of vital importance to read this information carefully to understand the operating of the machine and its conditions of use. Its purpose is to enhance user safety and prevent any breakdown caused by incorrect use of the insulation blowing machine.

WARNING! *This warns of situations that could give rise to serious injury if the instructions are not followed.*

CAUTION! *This provides information on how to prevent damage to the machine and/or avoid situations that could cause minor injury.*

NOTE. *This provides relevant information on the procedure described.*

Read this manual carefully for a fuller understanding of the machine and its procedures. Following the instructions and recommendations contained in the manual will reduce potential risk of accident during the installation, use and maintenance of the machine, and will enable you to obtain better performance and trouble-free functioning for a longer time and quickly and simply detect and solve any problems that may arise.

Keep this Service Manual in a safe place for future consultation. If you lose the manual you may order a new copy from your local **HI-TECH** dealer or by directly contacting **HI-TECH SPRAY EQUIPMENT, S.A.**

WARNING! *The novaG-fill 60 and novaG-fill 60-G insulation blowing machine are not designed to be used in potentially explosive atmospheres or exceed the pressure limits indicated in the technical specifications in this manual.*



Suitable clothing and personal protection elements must be worn on operating this machine. These include, but are not limited to, gloves, protective goggles, safety footwear and a face mask. Safety measures to be implemented and complied with should not be limited to those described in this manual. Before starting up the machine, a rigorous risk analysis should be carried out with regard to the material to be processed, the type of use and the working environment.



To prevent personal injury caused by incorrect handling of the raw materials and products used in the process, please carefully read the safety information provided by your supplier.



To prevent any damage caused by compressed air impact, do not open any connections or carry out any maintenance work on pressurised components until the pressure has been totally released.

Use suitable protection when carrying out machine operation and maintenance work and whenever you are in the machine's operating area. This includes, but is not limited to, wearing a face mask, protective goggles, safety gloves, safety footwear and safety clothing.



The machine's engine can become very hot and may cause burns. Do not handle or touch any hot parts of the engine until they have cooled down.

Carefully read all the technical and safety documentation included in the engine service manual.



To prevent serious injury (serious blows or amputations), do not work with the machine unless the safety guards have been duly installed on the moving parts. Ensure all the safety guards are correctly fitted back onto the machine again on finishing any repair or maintenance work.

The positive displacement air blowers are noisy (continuous A-weighted sound pressure from the acoustic reading is 85 dB). The use of ear protection is recommended and may be mandatory in accordance with the applicable EU directive concerning workplace noise exposure.

The blower housing can become very hot. Do not touch it until you are sure it has cooled down.



Carefully read all the technical and safety documentation included in the blower service manual.

If you operate the blower with the tubes disconnected, you must fit a thick, resistant screen over the outlet and avoid standing in the discharge or suction area of the machine while it is running.

The waste generated must be managed in accordance with the applicable regulations in each country.



Disconnect the machine from the electrical mains before carrying out any operation inside the electric console.

Electrical maintenance of the machine must only be carried out by a specialist technician.



MAIN CHARACTERISTICS

Mineral wool is a non-combustible insulating material with very low thermal conductivity, specially developed for thermo-acoustic insulation of cavities by mechanical blowing.

The **novaG-fill 60** and **novaG-fill 60-G** insulation blowing machines were designed and built for quick, reliable blowing of mineral wool and other types of fibre.

On manufacturing this insulation blowing machine, special attention was paid to selecting the commercial component suppliers and to the quality and precision of the parts produced at HI-TECH SPRAY EQUIPMENT, S.A., with a view to obtaining exceptional performance on small and medium range production.

Its compact design consists of a single frame integrating the hopper, spindles, turbine, air chamber (airlock), diesel motor, blower, transmission system and electric cabinet, with total accessibility of all components and ease of inspection and maintenance work.

Two spindles agitate the wool in the hopper and convey it to the area containing the interlocking spindles, which are equipped with rods to break up the material. It then falls through the opening in the two adjustable gates. Two shafts with different rotation directions, equipped with four blades, convey the wool into the six-blade turbine, from where it is conveyed to the sealed pumping and pressure chamber, guaranteeing a constant flow of wool.

The conveyor spindles, the interlocking spindle, the four-bladed shafts and the turbine are all synchronised by mechanical transmission.

The wool is propelled from the sealed chamber through the hoses to the injection head using the compressed air provided by the blower. A manual valve on the head opens and closes the flow of wool to the injection nozzle.

To facilitate the operator's work, the machine has a wireless remote control with a range of 150 metres, or, optionally, a remote control with a 45-metre cable.



TECHNICAL SPECIFICATIONS

MACHINE	
Height	1765 mm
Width	850 mm
Length	2100 mm
Weight	950 kg
Total surface area	1.78 m ²
Production with Ø 70 mm hoses	7 kg/minute
Production with Ø 50 mm hoses	4 kg/minute
Hopper capacity	1000 litres

Progressive discharge AIRLOCK	
Diameter	300 mm
Length	370 mm
Total chamber volume	24 litres
Pumping chamber volume	4 litres
Input connector diameter	60 mm
Output connector diameter	100 mm

THREE LOBE POSITIVE DISPLACEMENT BLOWER	
Volume of air supplied @ 3000 rpm	380 m ³ /hour @ 200 mbar (5.8 m ³ /min)
Volume of air supplied @ 3000 rpm	330 m ³ /hour @ 300 mbar (5.5 m ³ /min)
Absorbed power @ 3000 rpm	3 kW @ 200 mbar
	5 kW @ 300 mbar
Maximum differential pressure (blowing)	1000 mbar
Maximum differential pressure (suction)	500 mbar
<i>For more information, see the blower service manual</i>	

**LOMBARDINI LDW 1003 DIESEL ENGINE**

Nº of cylinders	3, in-line
Cylinder capacity	1028 cm ³
Power	15.5 kw @ 2200 rpm
Maximum torque	59 Nm @ 2200 rpm
Oil sump capacity	2.3 litres
Fuel tank capacity	29 litres
Fuel	Diesel fuel
Fuel specifications	ASTM D-975-1D or 2D, EN590 or equivalent
Battery	74 Ah 12 V
Radiator heat dissipation	16,500 kcal/hour
Electro-fan connection temperature	90 °C
Electric fan disconnection temperature	80 °C

For more information, see the engine service manual

ALTERNATOR (MODEL novaG-fill 60-G ONLY)

Voltage	2-pole, single-phase, 115/220 V
Power	6.5 kVA
Frequency	50 Hz
rpm	3000

A-weighted sound pressure level: _____ 85,0 dB (A)

A-weighted sound power level: _____ --, - dB (A)

Values obtained according to UNE-EN ISO 3746:1995 standard.



DESCRIPTION OF MAIN COMPONENTS

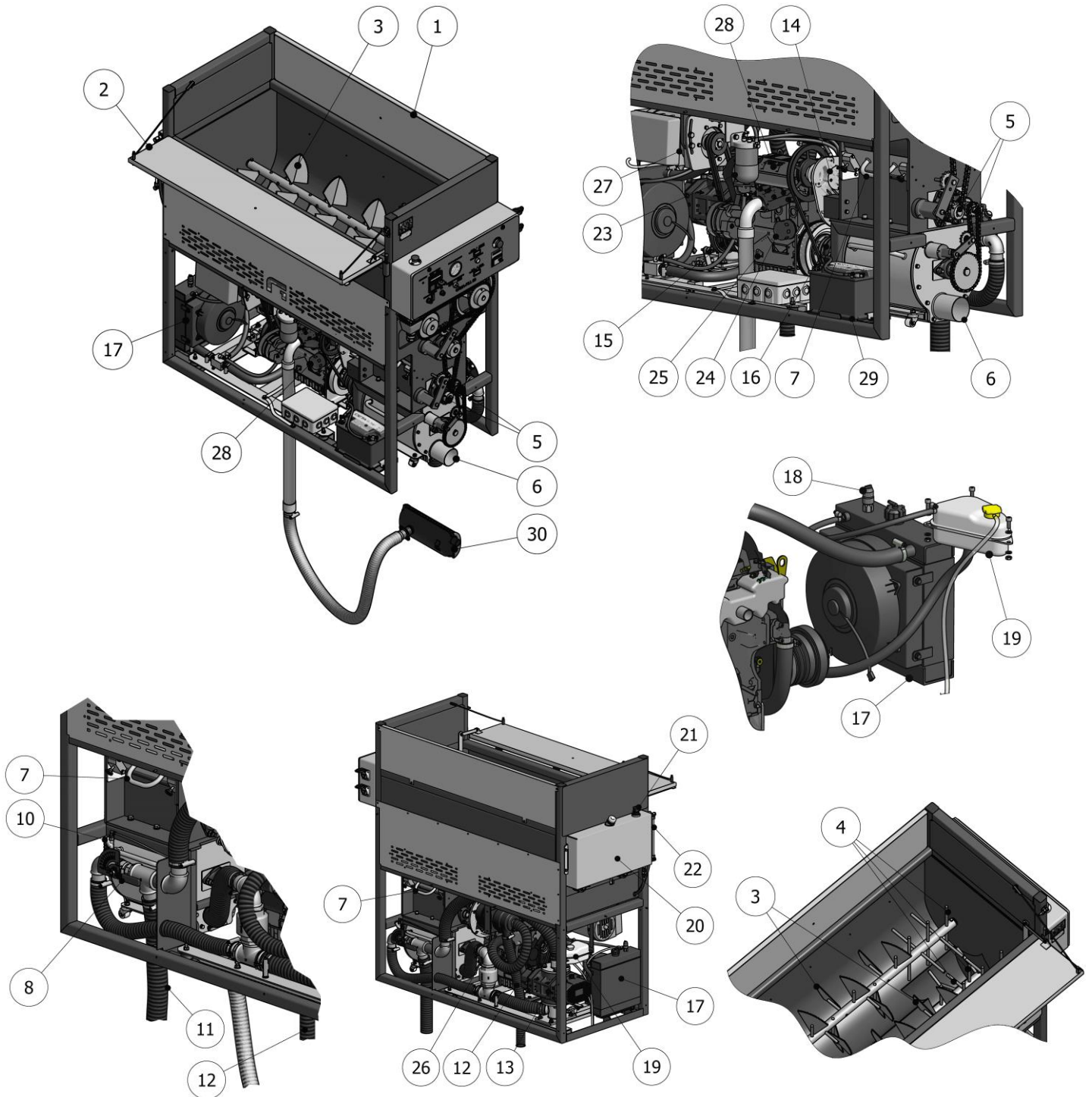

Figure 1. Description of the Main Components of model novaG-fill 60



1. Hopper

With its adjustable gates closed, the hopper has a capacity of 1000 litres, or approximately 1½ bags of wool.

WARNING! *Never put your hand inside the hopper unless it has been disconnected or the engine has been switched off.*

2. Wool Loading Door

When the door is unbolted it folds down 90° and remains in horizontal position.

Folding down the door activates a safety switch that automatically releases the two clutches: the blower clutch and the mechanical transmission clutch.

WARNING! *For compliance with EU load-handling regulations, we recommend cutting the bags of wool in half before placing them on the door.*

CAUTION! *We recommend securing the bag cutting tool to the machine frame with a rope or chain, to prevent damage to the system if it accidentally falls onto the spindles.*

3. Conveyor Spindles

These convey the wool to the breakup area.

4. Agitator Spindles

These spindles, together with the lower interlocking spindle, even out the wool and break it up for ease of processing.

5. Turbine Feed Shafts

The two shafts rotate in opposite directions, guaranteeing a constant, even flow of wool towards the six-blade turbine.

6. Airlock

The machine contains a six-blade turbine, which has a dual purpose: it conveys the wool from the breaking area to the sealed pumping chamber and, additionally, its design and the blade material ensure the chamber remains correctly sealed. As a result, all the pressure and air flow from the blower is directed exclusively towards the hoses.

The airlock's exclusive design means only 10-15 minutes are required to replace the airlock with a new one when maintenance work is carried out, e.g. replacement of the rubber blade seals.

WARNING! *Never place any objects or stand in front of the air outlet tube unless the machine has been disconnected or the engine switched off.*



7. Adjustable Gates

These enable the wool flow and density to be controlled by opening or closing the space the wool falls through into the turbine.

If the gates are completely closed, the wool can be agitated and broken up inside the hopper for as long as required.

The space the wool falls through can be very accurately regulated by loosening the knobs, using the millimetre scale as a guide.

The exclusive design of the closure system prevents the material from falling out of the hopper.

8. Discharge Valve

WARNING! *It is vital to ensure that this valve is not totally closed before starting up the blower.*

Depending on the metres of hose used, this valve is used to regulate the air flow and air pressure conveying the wool through the hose to the injection head. The wider the opening, the lesser the air flow conveyed through the hose.

NOTE This valve is also used as a safety device, to ensure that the air supplied by the blower has an escape route if the blasting hose is obstructed and the safety pressure switch fails.

9. Lower Manometer

This enables easy viewing of the discharge valve pressure adjustment.

10. Manometer Filter

This filter prevents solid particles from entering the manometer and the pressure switch to prevent them becoming blocked.

It is supplied with a standard 30 mesh screen.

11. Blower Air Suction Nozzle

CAUTION! *It is vital to ensure that only clean air is sucked into the nozzle and that no solid particles enter it.*

To do this, connect a section of the hose that will suck in the air below the vehicle platform. The hose is supplied with the machine.

12. Engine Air Suction Nozzle

CAUTION! *It is vital to ensure that only clean air is sucked into the nozzle and that no solid particles enter it.*

To do this, connect a section of hose that will suck in the air below the lorry or trailer platform. The hose is supplied with the machine.



13. Blower

The blower can blast air at a maximum pressure of 1000 mbar. It freely conveys the wool fed to it by the turbine to the injection head, at a constant flow and pressure.

To prevent blockage due to material accumulating in the chamber, it is essential for the blower to be functioning before the mechanical transmission is activated by pressing the **AIR & FIBRE** button on the remote control. This guarantees the air pressure in the pumping chamber.

There is a timer inside the electric cabinet for this purpose, adjustable from 0 to 12 seconds.

The machine comes with a mechanical transmission delay time of 3 seconds programmed by default. We do not recommend changing this time.

WARNING! *If you operate the blower with the tubes disconnected, you must fit a thick, resistant screen over the outlet and avoid standing in the discharge or suction area of the machine while it is running.*



Before starting up the blower, carefully read all the technical and safety documentation in the blower service manual supplied with each machine. Special attention must be paid to this information in order to understand the operating of the blower and its conditions of use. Its purpose is to enhance user safety and prevent any breakdown caused by incorrect use.

14. Swinging Reducer

This reduces the rpm of the engine's output to the mechanical transmission drive shaft. Reducers of this type are permanently lubricated and are supplied by default with refined oil, and they therefore require no maintenance.

15. Blower Clutch

When the **AIR ONLY** button or the **AIR & FIBRE** button on the remote control are pressed, the engine power is connected and transmitted to activate the blower.

When the emergency button is pressed or the hopper door is opened, it is automatically disconnected.

16. Mechanical Transmission Clutch

If the **AIR & FIBRE** button on the remote control is held down for 3 seconds, the engine power is connected and transmitted to activate the mechanical transmission.

When the emergency button is pressed or the hopper door is opened, it is automatically disconnected.

17. Radiator

The radiator sucks in the air from the underside of the vehicle. The electric fan and the recirculation system pump start up when the coolant in the engine reaches a temperature of 90 °C, and they stop when it falls to 80 °C.

There is a filter in the suction area to prevent solid particles from entering the radiator fins.

This filter must be cleaned daily using compressed air.

The radiator heat dissipation is 16,500 kcal/hour.



Service Manual

WARNING! *The cooling circuit contains liquid under pressure. Do not carry out any inspection until the engine has cooled down, and even after cooling open the radiator or expansion tank cap with care.*

Do not go too close to the radiator when the engine is still hot, as the electric fan could start up, even if the engine is not running.

18. Thermostat

In cold weather, cold water from the heat exchanger should not flow towards the engine block between engine start-up and the ideal operating temperature being reached (85-90 °C). A thermostat has therefore been provided in the upper part of the heat exchanger to automatically detect the temperature of the coolant.

It is calibrated to a minimum of **80 °C** and a maximum of **90 °C** by defect.

This means that when the coolant in the engine reaches 90 °C it sends an electric signal to the machine processor so that the radiator electric fan starts up automatically, and when it drops to 80 °C it sends a signal for it to stop.

19. Expansion Tank

In addition to facilitating coolant filling, the expansion tank also absorbs the excess liquid and the pressure in the closed motor cooling circuit. The tank enables the cooling circuit to maintain the correct volume of coolant even if it expands and contracts on heating and cooling.

The tank cap has a valve calibrated to 0.7 bars which limits the pressure in the circuit when the liquid expands.

The total tank capacity is 1.3 litres.

WARNING! *ON FILLING THE TANK WITH COOLANT, TAKE SPECIAL CARE NOT TO EXCEED THE LEVEL INDICATOR. ONLY FILL IT UP TO THE MARK.*

WARNING! *The cooling circuit contains liquid under pressure. Do not carry out any inspection until the engine has cooled down, and even after cooling open the expansion tank cap with care.*

20. Fuel Tank

The tank has a capacity of 29 litres of **DIESEL FUEL**. With a full tank, the engine can run for approximately 12 hours.

It has an electronic level indicator and a visual level indicator. When the indicator light on the engine control panel comes on, this means that there is a reserve of approximately 7 litres of diesel fuel in the tank. This will allow the engine to run for around 3 hours.

NOTE *Purchase the fuel in small amounts and store it in suitable, clean containers. Clean fuel prevents the injectors from becoming obstructed.*

Do not fill the fuel tank completely. Leave some space for the fuel to expand. When filling the tank, clean up any fuel spills immediately.



Never allow the tank to drain completely, to avoid having to bleed the air from the fuel system.

Fill up with fuel at the end of each day, to prevent condensation from forming at night. Diesel fuels complying with the specifications ASTM D-975 – 1D or 2D, EN590 or equivalent are suitable for use with this type of engine.

For more information, see the engine service manual.

WARNING! *Never store fuel in galvanised containers, as the fuel and the galvanized container would produce a chemical reaction and clot, which would quickly obstruct the filters or cause the injection pump and injectors to fail.*

21. Fuel Tank Electric Level Indicator

When the indicator light on the engine control panel comes on, this means that the amount of diesel fuel remaining in the tank is approximately 7 litres. This will allow the engine to run for around 3 hours.

22. Fuel Tank Visual Level Indicator

This indicator gives a visual indication of the fuel level in the tank. Refill to the level of the upper connector.

23. Fuel Filter

The main purpose of this filter is to retain any impurities in the fuel, which will be trapped in the filter paper. It also obstructs the flow of free or emulsified water, preventing it from reaching the injection system.

The water is conveyed to the bottom of the filter tank. This water can be drained by loosening the wing nut on the underside of the tank.

The solenoid valve on top of the filter opens or shuts off the fuel flow to the injection system. This valve is normally closed, only opening when the starter motor is activated via the control panel.

When an emergency button is pressed, the solenoid valve shuts off the fuel flow to the engine, causing it to stop. *Read the engine service manual.*

24. Engine Oil Filter

The purpose of this filter is to retain any impurities in the engine lubrication circuit. *Read the engine service manual.*



Service Manual

25. Engine Oil Level

The machine is supplied with oil by default.

When it needs refilling, remember the oil must comply with the characteristics and specifications indicated in the engine service manual. *Read the engine service manual.*

NOTE: *Oil filling and level checking must be done on flat ground. Change the oil again after the first 50 hours of engine functioning. Read the engine service manual.*

WARNING! *Never add oil when the engine is running.*

26. Engine Air Filter

The main purpose of this filter is to retain any impurities in the air suction system. It must be replaced when the indicator light on the control panel comes on.

27. Auxiliary Alternator (model novaG fill-60-G only)

The generator transforms the mechanical power supplied by the engine into electric power. The nominal voltage is 115/230V single-phase, and the frequency is 50 Hertz. This voltage supplies 2 electrical sockets, with a power of 3.3 kW and 16 Amp.

28. Engine

The machine is equipped with a water-cooled Lombardini LDW 1003 engine.

It has 3 cylinders in line and a total cylinder capacity of 1028 cm³. It generates 15.5 kW power at 2200 rpm.

The mechanical power supplied activates the blower, the mechanical transmission and on **NOVAG FILL-60-G** machines the auxiliary alternator.

The model, serial number and characteristics figure on the reference plate. You will need to state the engine model and serial number on ordering spares.



Before starting up the engine, carefully read all the technical and safety documentation in the engine service manual supplied with each blasting unit. Special attention must be paid to this information in order to understand the operating of the engine and its conditions of use. Its purpose is to enhance user safety and prevent breakdowns caused by incorrect use.

29. Battery

The battery supplies the power required for engine start-up.

Visual inspection of the hydrometer in the battery cover will indicate one of three states:

- **Green dot:** State of charge 65% or over.
- **Black dot:** State of charge less than 65%. You should recharge the battery immediately.
- **White dot:** Electrolyte low. The reason for this is that the battery has been overcharged with excessive voltage for a long period. The battery will need replacing.

30. Exhaust Pipe

Fit the exhaust pipe to the outer underside of the vehicle and fix it in place with a flange (not supplied with the unit).

ELECTRICAL CABINET

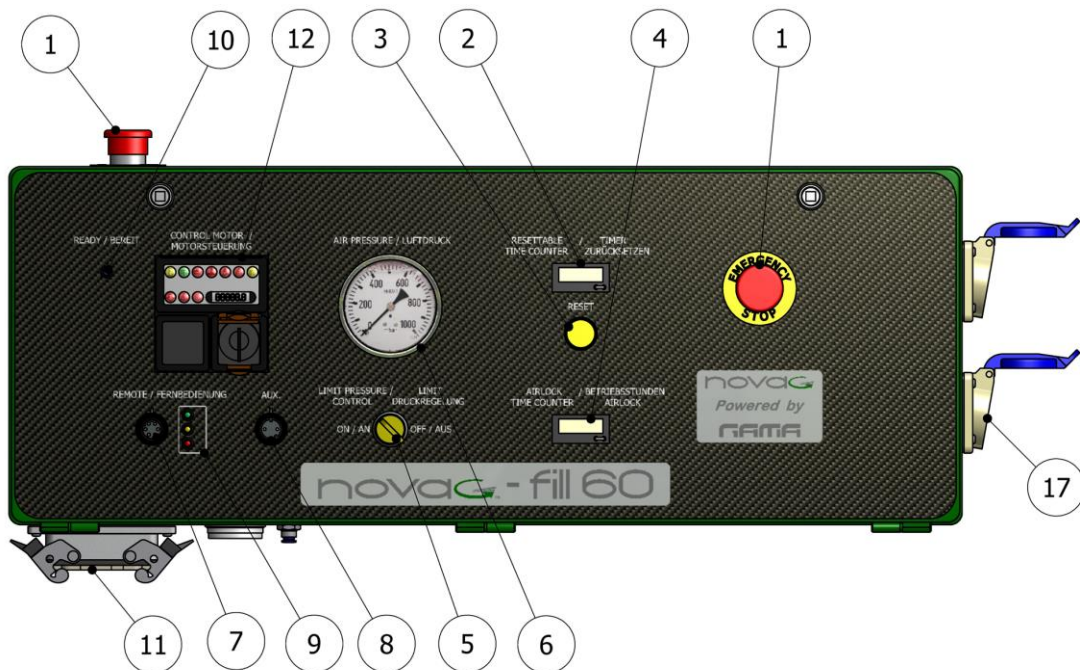

1. Emergency Buttons

If these buttons are pressed they cut off the supply of fuel to the engine and it will stop. When an emergency button is pressed it is mechanically fixed in **STOP** position and will need to be reset manually. (Turn the button counter-clockwise to do this).

2. Partial Injection Time Counter

This shows the seconds the injection process has taken. The time starts to count down when the mechanical transmission clutch is engaged. The mechanical transmission process begins 3 seconds after the operator presses the **AIR & FIBRE** button on the remote control and starts up the blower. The timer stops counting if the **STOP** button on the remote control or an emergency button is pressed, or if the pressure switch calibrated to 350 mbar is triggered. The time unit is seconds and the measurement range is 0 - 99999.9 seconds, increasing by 0.1 second intervals. If the **RESET** button is not pressed after each injection, the seconds will continue to count up.

3. RESET Button

Press this button to set the injection time counter to zero.



Service Manual

4. Total Airlock Functioning Time Counter

This counts up the total hours of **AIRLOCK** functioning, which will appear on the display. It begins to count when the mechanical transmission is started up for the first time, increasing as functioning progresses.

The time unit is hours, and the measurement range is 0 - 99999.99 hours, increasing by 1 minute intervals.

5. High Pressure Control Selector

To enable the high pressure control system, select the option "**ON**". The selector will remain lit. When the default pressure limit (350 mbar) is reached, both clutches (the blower clutch and the mechanical transmission clutch) will be disengaged.

CAUTION! *The overpressure control should always be enabled while you are working, as overpressures higher than 350 mbar could block the hose.*

6. Manometer

This shows the pressure at which the material is being injected.

7. Remote Control Connector

This connector is for connecting the wireless or wired remote control.

8. Auxiliary Connector

This is a potential-free connector that sends an electric signal to a component external to the machine.

9. LED indicators

These indicate that the remote controls are functioning correctly. They switch on and off according to the buttons pressed on the wireless or wired remote control.

The red LED lights up when the key is inserted in the ignition in position 1 and turned to position 2 to start up the engine, and it switches off when the **STOP** button on the remote control is pressed.

The green LED lights up when the **AIR ONLY** button on the control is pressed. It remains lit while the button is held down.

The yellow LED lights up when the **AIR & FIBRE** button on the remote control is pressed. It remains lit while the button is held down.

10. LED Ready

This LED lights up to indicate that the whole electric system is **OK** and the machine is ready to work.

It lights up 8 seconds after the key is placed in the ignition in position 1, or 8 seconds after the engine is started up (key in position 2).

11. Multi Connector

The multi-connector facilitates maintenance work in the electrical cabinet and quick change in case of breakdown.



12. Engine Control Panel

This panel contains all the engine control indicator lights, the operating time counter and the ignition.

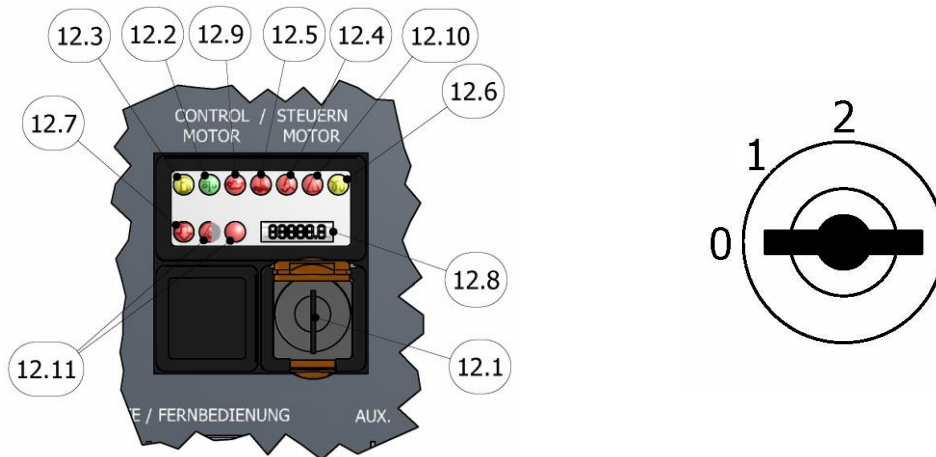

12.1 Engine ignition

- Turn the ignition key clockwise to position 1. The red LED will light up.
 - Wait until the spark plug firing indicator light switches off.
 - Turn the ignition key clockwise again to position 2.
 - Ensure that when the engine is running all the indicator lights are off and only the engine protection indicator light (🛑) remains on.
- When 8 seconds have elapsed the blue “Ready” LED will come on to show that the machine is ready for the blower and mechanical transmissions to start up.

CAUTION! Do not rev the starter motor for more than 20 seconds continuously. If the engine does not start up, wait for 1 minute before repeating the manoeuvre. If the engine does not start up after two consecutive attempts, consult the engine service manual to find out the cause of the problem.

12.2 Engine protection indicator light (green LED) (🛑)

This LED comes on when the engine is running and all the other indicator lights are switched off. If everything is functioning correctly, the indicator light will remain on while the engine is running.

If any of the three major engine anomalies are detected – low oil pressure (🛑), coolant temperature too high (🛑) or air filter obstructed (🛑) – the engine protection light will switch off and the indicator light for the anomaly in question will come on. If this indicator light remains on for 3 seconds, the engine will stop.



Engine stoppage is caused by the solenoid valve on the fuel filter, which cuts off the supply of fuel to the injection system.

12.3 Fuel level indicator light (yellow LED)

This light comes on when the fuel level is low.

The amount of diesel fuel remaining in the tank is approximately 7 litres. This means the engine can run for around 3 hours.

12.4 Battery charge indicator light (red LED)

This indicator light comes on when the battery is not charged.

If it remains on for 3 seconds, the engine will stop.

12.5 Water temperature or engine head temperature indicator light (red LED)

This indicator light comes on when the temperature of the coolant exceeds a safety threshold.

If it remains on for 3 seconds, the engine will stop.

12.6 Spark plug indicator light (yellow LED)

This indicator light flashes if there is no supply to the spark plugs (the fuse has blown or the relay has failed).

12.7 Air filter blockage indicator light (red LED)

This indicator light comes on if the air filter is blocked.

12.8 Time counter display



This shows the engine running time in hours and tenths of an hour.

12.9 Engine oil pressure indicator light (red LED)

This indicator light comes on when there is insufficient oil pressure. If it remains on for 3 seconds, the engine will stop.

12.10 Auxiliary alarm indicator light (red LED)

This indicator light does not have a specific function. It is programmable so that any other alarm required may be added.

12.11 Auxiliary warning lights (red LEDs)

These indicator lights do not have a specific function. They are programmable so that any other warning signal required may be added.



Before starting up the engine, carefully read all the technical and safety documentation in the engine service manual supplied with each blasting unit. Special attention must be paid to this information in order to understand the operating of the engine and its conditions of use. Its purpose is to enhance user safety and prevent any breakdown caused by incorrect use.

13. Wireless Remote Control

This system consists of a remote control (transmitter) and a receiver. Its range is 150 metres.

The receiver has 5 metres of cable with a connector to connect it to the socket in the electrical cabinet.

The receiver is normally fitted to the vehicle wall, close to the machine.

The remote control has three functions which are enabled and disabled by means of its three buttons.

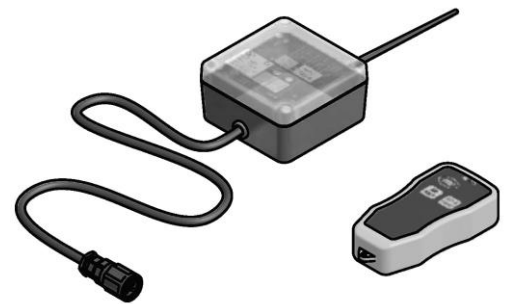

“AIR ONLY” Button

This button is pressed to activate the blower clutch.

“AIR & FIBRE” Button

This button is pressed to activate both the blower and mechanical transmission clutches.

The mechanical transmission is enabled 3 seconds later than the blower.

“STOP” Button

This button is pressed to disable either the blower or both the blower and the mechanical transmission.

A red LED indicator light on the remote control lights up whenever any of the buttons is pressed.

If the remote control is not working and the LED does not come on, check the receiver is correctly plugged into the electrical cabinet connector. If it is correctly plugged in, replace the control battery.

The remote control battery should be replaced yearly.

If the LED comes on but the remote control does not work when the **AIR ONLY** or **AIR & FIBRE** buttons are pressed, check that the green LED or the yellow LED are lit in the electrical cabinet. If they are not, this means the receiver is not correctly receiving the signal from the remote control.

If this is the case, place the receiver outside the vehicle cabin. The 5-metre cable can reach any part of the vehicle from outside the cabin.

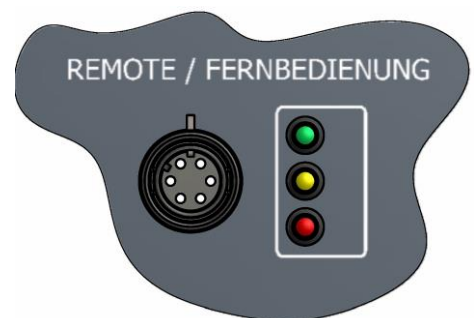



14. Wired Remote Control

The system consists of an electric remote control with 45 metres of cable and a connector to connect it to the socket in the electrical cabinet.

The control has three functions which are enabled and disabled by means of its three buttons.

“Air Only” Button

This button is pressed to activate the blower clutch.

“AIR & FIBRE” Button

This button is pressed to activate both the blower and mechanical transmission clutches.

The mechanical transmission is enabled 3 seconds later than the blower.

“STOP” Button

This button is pressed to disable either the blower or both the blower and the mechanical transmission.

If neither the blower nor the mechanical transmission work when the **AIR ONLY** or **AIR & FIBRE** buttons are pressed, check the cable is correctly connected in the electrical cabinet.

15. Safety Pressure Switch

This disengages the blower clutch if the default pressure is exceeded.

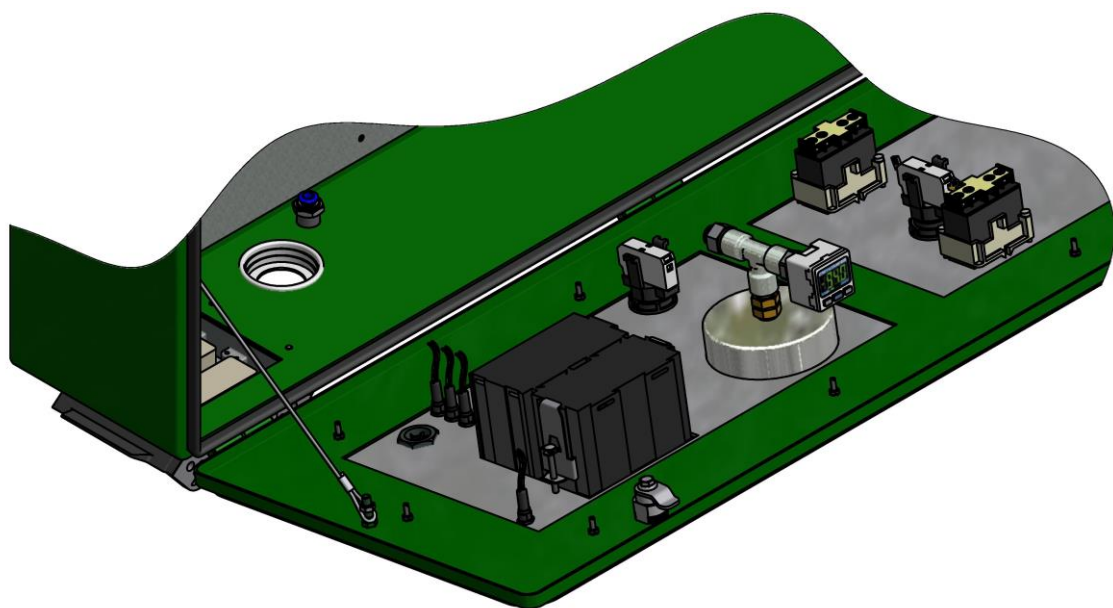
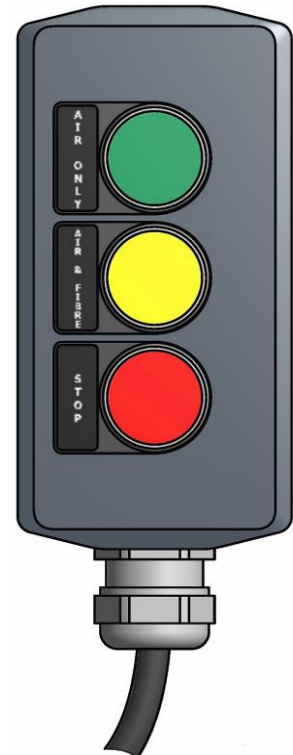

Default pressure: 350 mbar, with a tolerance of +/- 10 mbar



16.Timer

This allows you to select the seconds of delay between mechanical transmission start-up and blower start-up. It can be adjusted between 0 and 12 seconds.

When the timer is activated the green LED comes on. When the selected time has elapsed, the orange LED comes on and then switches off again. All the LEDs should be off at this stage.

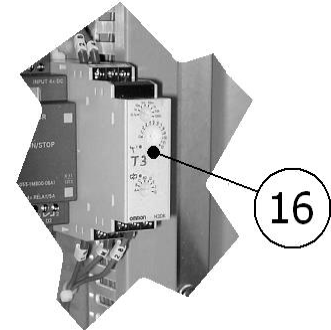

17.Auxiliary power (optional)

Available 2 sockets 220v outlets. Only for **novaG-fill 60-G**.

BEFORE START-UP

The machine has a pack of accessories required for assembly. Ensure you have received all the components listed below:

1. 3 sections of Ø 2" hose, 15 metres in length
2. 1 section of Ø 1.5" hose, 15 metres in length
3. 1 section of Ø 4" hose, 0.75 metres in length
4. 1 section of Ø 3" hose, 0.75 metres in length
5. 1 section of Ø 2.5" hose, 0.75 metres in length
6. 1 section of Ø 50 mm metal hose for the exhaust pipe, 2 metres in length
7. 1 section of Ø 60 mm hose for blower suction, 0.75 metres in length
8. 1 section of Ø 50 mm hose for air filter suction, 0.75 metres in length
9. One 4"-3" hose connector
10. One 3"-2.5" hose connector
11. One 2.5"-2" hose connector
12. Two 2"-2" hose connector
13. One 2"-1.5" hose connector
14. Two Ø 4" hose flange
15. One Ø 3" hose flange
16. One Ø 2.5" hose flange
17. Seven Ø 2" hose flanges
18. Two Ø 1.5" hose flanges
19. Two Ø 50 mm metallic hose flanges
20. One Ø 60 mm hose flange
21. One 2" hose injection head with Ø 22 mm nozzle
22. One 1.5" hose injection head with Ø 17 mm nozzle
23. 1 exhaust pipe
24. 1 injection test box
25. 1 dynamometer
26. 1 raffia bag for weighing



Service Manual

27. 1 wireless remote control consisting of a transmitter and a receiver
28. 1 remote control with 0.5 metres of cable
29. One 45 metre extension cable for the remote control
30. One Cutter
31. 1 key for deactivating the flap door safety micro switch
32. 2 keys for engine turn on
33. 1 engine service manual
34. 1 Lombardini official world technical assistance service book
35. 1 blower service manual
36. 1 machine service manual
37. 1 machine component identification manual
38. 1 timer instructions manual
39. 1 pressure switch instructions manual
40. 1 dynamometer instructions manual
41. 1 flap door safety micro switch instructions manual
42. 1 alternator instructions manual (model novaG fill 60-G machines only)
43. 1 packaging

Optional components:

- Metal wool holder
- Endoscope
- Hose winding spool
- Ø 2.5" hose
- 2" hose injection head with Ø 20 mm nozzle
- Display panel for demonstrations
- Extractor tool for rubber seal replacement
- Earth cable



INSTALLATION IN THE VEHICLE

CAUTION! Before starting up the machine, it must be firmly secured to the cross beams on the vehicle floor, using at least 4 fixing points.

- Open an air inlet of approximately 330 x 140 mm in the vehicle floor for the heat exchanger.
- Open two air inlets of approximately 185 x 540 mm and 200 x 540 mm in the vehicle floor for the engine.
- Drill a \varnothing 65 mm hole in the vehicle floor for the blower suction hose.
- Drill a \varnothing 55 mm hole in the vehicle floor for the engine air filter suction hose.
- Drill a \varnothing 65 mm hole in the vehicle floor for the exhaust pipe hose.
- Drill a \varnothing 25 mm hole in the vehicle floor for the coolant removal tubes.

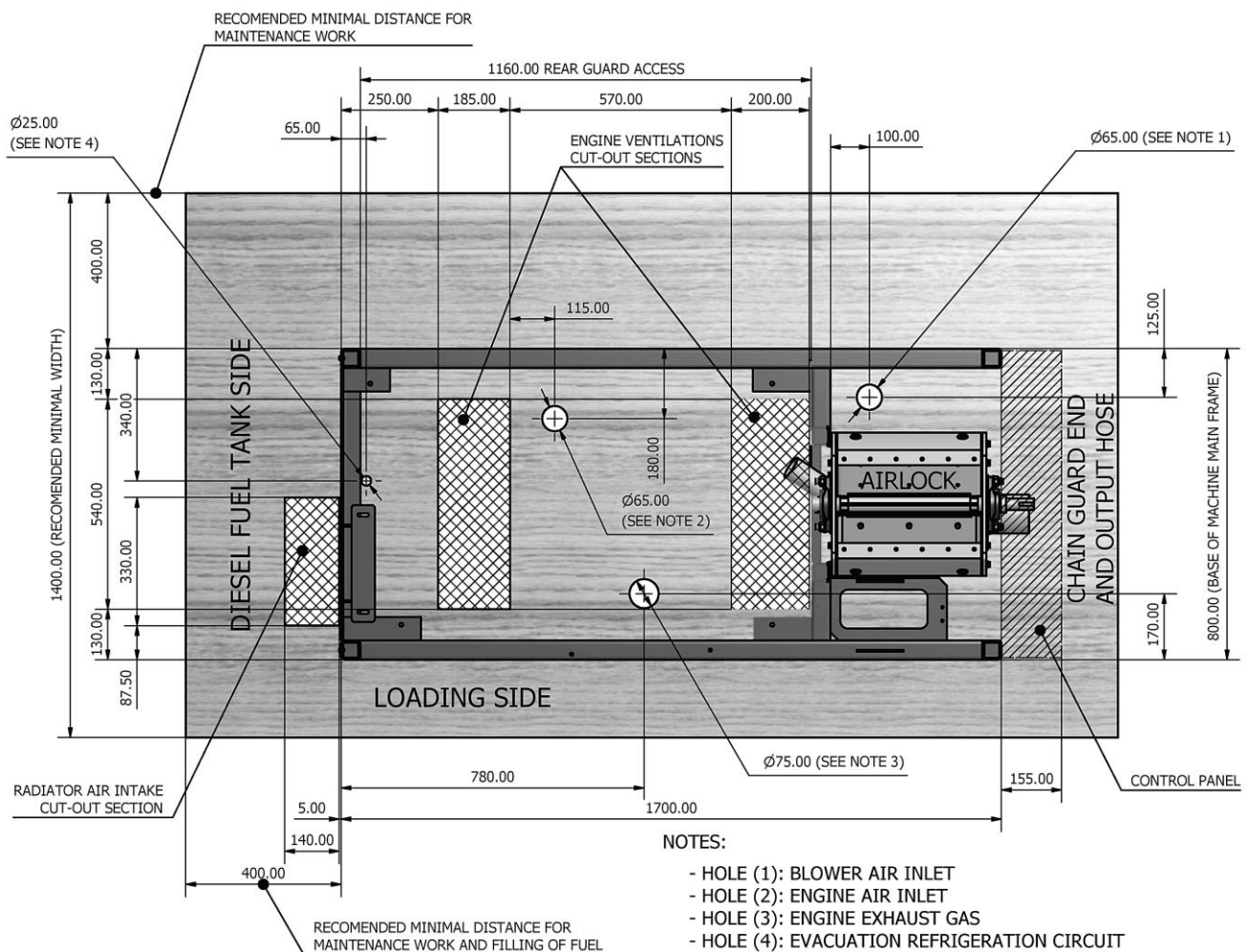



INITIAL START-UP

WARNING! To prevent personal injury caused by incorrect handling of the raw materials and products used in the process, please carefully read the safety information provided by your supplier.

Use suitable protection when carrying out machine operation and maintenance work and whenever you are in the machine's operating area. This includes, but is not limited to, wearing a face mask, protective goggles, safety gloves, safety footwear and safety clothing.

- a) Fill the fuel tank with **DIESEL FUEL** (the machine is supplied with an empty tank). The capacity is approximately 29 litres. The **DIESEL FUEL** must comply with the characteristics and specifications indicated in the engine service manual. *Read the engine service manual.* Ensure that the shut-off valve for opening and closing the flow of fuel to the engine is open.

NOTE: Do not fill the tank to its maximum capacity (29 litres). Always leave a space of 2-3 cm at the top of the tank neck to allow for fuel expansion. If any fuel is spilt during filling, clean the entire area around the tank.

WARNING! Never add fuel while the engine is running or in a closed space, as this could result in inhalation of toxic gases.

- b) Check the oil sump level and fill it up to its maximum level if necessary (the machine is supplied with a full oil sump). The oil must comply with the characteristics and specifications indicated in the engine service manual. *Read the engine service manual.*

NOTE: Oil filling and level checking must be done on flat ground. Change the oil again after the first 50 hours of engine functioning. *Read the engine service manual.*

WARNING! Never add oil while the engine is running.

- c) Check the level of **COOLANT** in the tank and fill it up to the mark if necessary (the machine is supplied with a full tank). The total capacity of the expansion tank is 1.3 litres. The coolant must comply with the characteristics and specifications indicated in the engine service manual. *Read the engine service manual.*

WARNING! On filling the tank, take care to ensure you add coolant up to the mark on the bottle. For a correct reading, this should always be done with the engine cold.

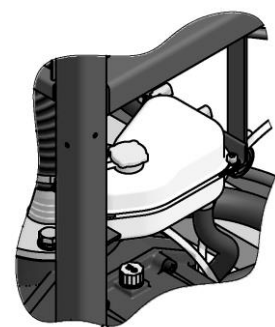
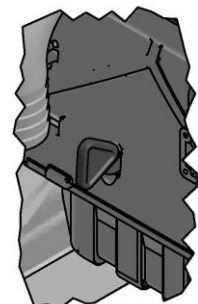
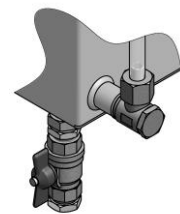



WARNING! The cooling circuit contains liquid under pressure when it is hot. Do not carry out any inspection until the engine has cooled down, and even after cooling open the radiator or expansion tank cap with care.

Do not go too close to the radiator when the engine is still hot, as the electric fan could start up, even if the engine is not running.

- d) Connect the hose to the blower suction connector and thread it through the Ø 65 mm hole in the vehicle floor.
- e) Connect the hose to the engine air filter suction connector and thread it through the Ø 55 mm hole in the vehicle floor.
- f) Unscrew the 2 nuts on the engine gas outlet flange. Fit the flange to the elbow and tighten the nuts to fix it in place. Connect the gas outlet hose to the engine connector and fix it in place with a flange. Thread the hose through the Ø 60 mm hole, connect the other end of the hose to the exhaust pipe and fix it in place with another flange. Position and secure the exhaust pipe to the outer underside of the vehicle, fixing it in place with a flange.
- g) Check that the oil level in the two gearboxes on the blower is up to the mark. *Read the blower service manual.*
- h) Clean the battery terminals (+ and -) and the flanges, using acid-free, acid-resistant grease. Connect the two battery flanges to their respective poles, the red cable to the positive pole and the black cable to the negative pole. Connect the negative pole first. When you have fitted the flanges, ensure they make good contact.
- i) Remove the front guard from the machine.
- j) Connect the 4" hose to the airlock outlet socket and firmly tighten the fixing flange.
- k) Fit the front guard back onto the machine.
- l) Connect the 3" hose to the 4" hose via the corresponding connector and firmly tighten the two fixing flanges.
- m) Connect the 2.5" hose to the 3" hose using the corresponding connector and firmly tighten the two fixing flanges.
- n) Connect the 15 metre section of the 2" hose to the 2.5" hose using the corresponding connector and firmly tighten the two fixing flanges.
- o) Connect the other 15 metre section of the 2" hose to the 2" hose using the corresponding connector and firmly tighten the two fixing flanges.
- p) Connect the injection head with a Ø 22 mm nozzle to the 15 metre section of the 2" hose and firmly tighten the two fixing flanges.

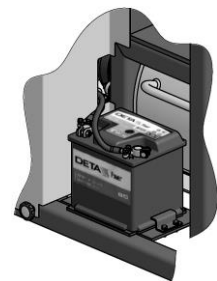
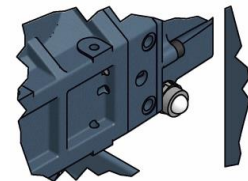
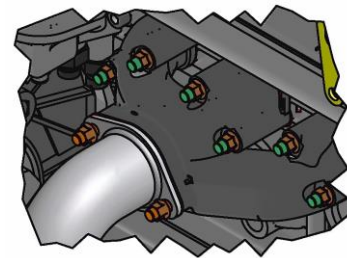



NOTE: The hoses and injection head must be configured according to the type of injection and the blowing distance.

On blowing, it is important for the hoses to be totally straight, preventing roll-up wherever possible, as this could cause overpressure in the blowing system with the consequent loss of charge capacity.

- p) Completely open the discharge valve. Depending on the metres of hose used, this valve is used to regulate the flow and pressure at which the wool is conveyed through the hose to the injection head. The wider the opening, the less air flow is conveyed through the hose.

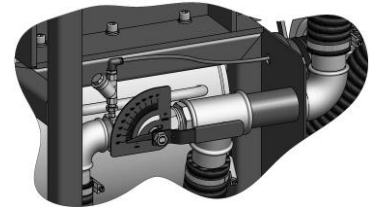

WARNING! It is vital to ensure that this valve is open before starting up the blower.

- q) Connect the wireless or wired remote control receiver to the connector in the electrical cabinet.
- r) If your remote control is wireless, locate a part of the vehicle wall you can fit it to.
- s) Check there are no foreign bodies in the hopper.
- t) Insert the key in the engine ignition in the electrical cabinet.
 - Turn the ignition key clockwise to position 1. The red LED will light up.
 - Wait until the spark plug firing indicator light switches off.
 - Turn the ignition key clockwise again to position 2.
 - Make sure that all the indicator lights are off when the engine is running, and that only the engine protection indicator light remains on.

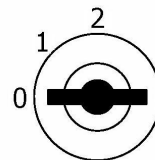

The blue “Ready” LED will come on after 8 seconds to show that the machine is ready for the blower and the mechanical transmissions to start up.



CAUTION! When the engine has started up, if everything is functioning correctly only the green engine protection indicator light should remain lit on the engine control panel. All the other indicator lights should be off. If everything is functioning correctly, the indicator light will remain on while the engine is running.

If any of the three major engine anomalies are detected – low oil pressure (🔴), coolant temperature too high (🔴) or air filter obstructed (🔴) – the engine protection light will switch off and the indicator light for the anomaly in question will come on. If this indicator light remains on for 3 seconds, the engine will stop.

CAUTION! Do not rev the starter motor for more than 20 seconds continuously. If the engine does not start up, wait for 1 minute before repeating the manoeuvre. If the engine does not start up after two consecutive attempts, consult the engine service manual to find out the cause of the problem.



Before starting up the engine, check that all the safety guards are in place and carefully read all the technical and safety documentation in the engine service manual supplied with each machine. Special attention must be paid to this information to understand the operating of the engine and its conditions of use. Its purpose is to enhance user safety and prevent breakdowns caused by incorrect use.

Ensure the exhaust pipe is outside the vehicle cabin. Never work with the engine running in a closed space as inhaling the exhaust gases could cause serious injury or even death.

- u) Press the “**AIR ONLY**” button on the wired or wireless remote control, to check the blower is functioning correctly. The green LED on the control panel will light up while you hold the button down.
- v) Press the “**STOP**” button on the wired or wireless remote control to stop the blower. The red LED on the control panel will switch off while you hold the button down.
- w) Press the “**AIR & FIBRE**” button on the wired or wireless remote control to check the blower and the mechanical transmission are functioning correctly. The blower will be activated first, followed by the transmission, 3 seconds later. The yellow LED on the control panel will light up while you hold the button down.

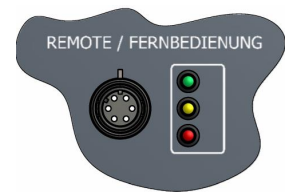

NOTE: A red LED indicator light on the remote control lights up whenever any of the buttons is pressed.

If the remote control is not working and the LED does not come on, check the receiver is correctly plugged into the electrical cabinet connector. If it is, replace the control battery.

In theory, the battery should last for several years.

If the LED comes on but the remote control does not work when the AIR ONLY or AIR & FIBRE buttons are pressed, check that the green LED or the yellow LED are lit in the electrical cabinet. If they are not, this means the receiver is not correctly receiving the signal from the control.



- x) Switch off the engine by turning the key counter-clockwise to “0”.
- y) Unbolt and open the hopper door.
Place the bag of wool on the door, cut the bag open and empty the wool into the hopper. Make sure the plastic bag has been completely removed.

WARNING! For compliance with EU load-handling regulations, we recommend cutting the bags of wool in half before placing them on the door.

CAUTION! We recommend securing the bag cutting tool to the machine frame with a rope or chain. This will prevent damage to the system if it accidentally falls onto the spindles.

- z) Close the hopper door.
- aa) The machine is now ready to blow the wool as required.



CALIBRATION

A box is supplied with the machine for testing the injection process before beginning to inject the wall itself.

This testing will give the operator a basic idea of the density of the material (kg/m³) and the flow from the machine (kg/minute).

The density obtained on injecting into the box is relative, and it will always be much higher than that obtained on injecting into the actual walls. It is approximately 1/3 higher.

The material must fill the entire box cavity, including the corners.

The average injection time will depend on the type of material used. The recommended times for Knauf materials are 25 - 40 seconds.

The volume of the box cavity is 0.01725 m³.

To calculate the density, divide the weight of the material injected into the box by the box cavity volume. For example, if the material injected weighs 1 kg, the density of the material will be $1 \div 0.01725 = 58 \text{ kg/m}^3$ (approx. 39 kg/m³ in the actual wall).

To calculate the flow in kg/minute, divide the weight obtained by the number of seconds required for the injection process, and multiply the result by 60. For example, if the material injected weighs 1 kg and the injection took 25 seconds, the flow obtained is $1 \div 25 \times 60 = 2.4 \text{ kg/minute}$.



Two workers are required for the calibration process. The process is as follows:

1. Adjust the gates, placing them both at 30% on the scale, for example.
2. Start up the engine.
3. Select the option “ON” on the high pressure control selector on the control panel.
4. Take the injection head and insert it in the raffia bag supplied with the machine. Roll the bag opening onto the injection nozzle to prevent the material being blown out of the bag when the injection process begins. Hold the bag and the nozzle firmly in place.
5. Open the manual injection head valve.

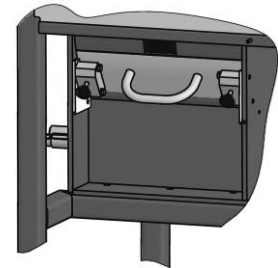

WARNING! Do not point the nozzle at your face or any other part of your body, or at other people.

6. Press the **AIR & FIBRE** button on the wired or wireless remote control. The blower will be activated immediately and the mechanical transmission will start up after 3 seconds. The material will start to run through the hoses and will come out of the nozzle towards the bag.
7. When the material begins to run through the hose another person should adjust the blowing pressure on the valve, turning it to around 34° on the scale, for example, which is equivalent to a pressure of approximately 220 mbar. The adjustment to 34° and the pressure of 220 mbar will depend entirely on the type of material being used, the size of the nozzle, the length and size of the hose and the gate adjustment.
8. Press the **STOP** button on the remote control to stop the blower and the transmission. The pressure has now been adjusted and the hose filled to perform calibration on the test box.



9. Empty the wool out of the bag and dispose of it in a suitable container. **DO NOT** empty it back into the hopper.
10. Press the time counter **RESET** button.
11. Stand the test box on the floor, resting against a wall.
12. Insert the injection nozzle in the hole in the centre of the box.
13. Press the **AIR & FIBRE** button on the remote control to start up the blower and the transmission.
14. Inject the material into the box. When the box is full, the system will be over pressured, and the high pressure switch calibrated to 350 mbar will send the electrical signal to deactivate both the blower clutch and the transmission clutch.
15. Use the dynamometer supplied with the machine to weigh the raffia bag (also supplied with the machine) to find out the calibration.
16. Empty the content of the box into the bag and weigh it with the dynamometer.
17. Check the seconds counted by the timer for carrying out the injection process.
18. Calculate the density and the flow supplied with respect to the time.
Note down all the data on the template on the following page of this manual, as a reference for the different applications.
19. Check the recommended weights and blowing times for the application in question in the material manufacturer's installation guides.

NOTE: *If the time, density or flow are not those recommended by the material manufacturer and you need to alter the pressure or adjust the gates again, never make these two changes at the same time: either change the gate adjustment or change the blowing pressure, but not both. This will avoid confusion on analysis of the results when you make a new calibration.*

20. If you will be making more calibrations, press the **RESET** button again to restart the time count.
21. If your next step is to blow into the wall, select the option “**OFF**” on the high pressure control on the control panel.
The machine will work in standard mode until the material flows into the holes in the wall.

NOTE: *For more information on the calibration process or the real wall blowing application procedure, read the installation and application guides provided by the material manufacturer.*

NOTE: *Do not load the material used for calibration into the hopper again. Dispose of it in a suitable container. The properties of material that has already been blown are different from those of unused material.*



DAILY START-UP PROCEDURE

WARNING! To prevent personal injury caused by incorrect handling of the raw materials and products used in the process, please carefully read the safety information provided by your supplier.

Use suitable protection when carrying out machine operation and maintenance work and whenever you are in the machine's operating area. This includes, but is not limited to, wearing a face mask, protective goggles, safety gloves, safety footwear and safety clothing.

WARNING! If the machine is located in a trailer type vehicle, before starting it up you should check that the hitch ball is in perfect condition, the trailer tyre pressure is correct and the trailer lights are all working.

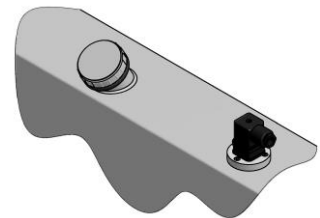

- aa) Check the fuel level in the tank and fill it up with **DIESEL FUEL** if necessary. The capacity is approximately 29 litres. The **DIESEL FUEL** must comply with the characteristics and specifications indicated in the engine service manual (read the engine service manual).

Ensure the shut-off valve for opening and closing the flow of fuel to the engine is open.

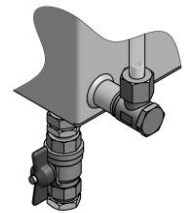

NOTE: Do not fill the tank to its maximum capacity (29 litres). Always leave a space of 2-3 cm at the top of the tank neck to allow for fuel expansion. If any fuel is spilt during filling, clean the entire area around the tank.

WARNING! Never add fuel while the engine is running or in a closed space, as this could result in inhalation of toxic gases.

- bb) Check the **OIL** sump level and fill it up to its maximum level if necessary. The oil must comply with the characteristics and specifications indicated in the engine service manual. *Read the engine service manual.*

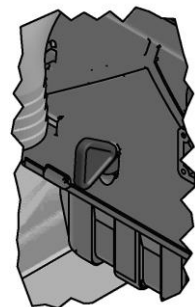

NOTE: Oil filling and level checking must be done on flat ground. Change the oil again after the first 50 hours of engine functioning (read the engine service manual).

WARNING! Never add oil while the engine is running.

- cc) Check the level of **COOLANT** in the tank and fill it up to the mark if necessary. The total capacity of the expansion tank is 1.3 litres.

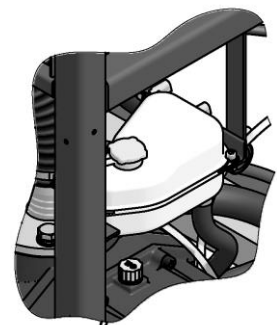



Service Manual

WARNING! On filling the tank, take care to ensure you add coolant up to the mark on the bottle. For a correct reading, this should always be done with the engine cold.

WARNING! The cooling circuit contains liquid under pressure. Do not carry out any inspection until the engine has cooled down, and even after cooling open the radiator or expansion tank cap with care.

Do not go too close to the radiator when the engine is still hot, as the electric fan could start up, even if the engine is not running.

- dd) Check that the oil level in the two gearboxes on the blower reaches the mark. *Read the blower service manual.*
- ee) Check the discharge valve is in the same position as it was the previous day. If it is not, position it correctly.
- ff) Check that the gates are in the same position as they were the previous day. If they have been closed or moved for any reason, place them in the same position on the scale.
- gg) Check the radiator and machine filters are clean. Clean them by compressed air blasting if necessary.
- hh) If the wireless or wired remote control receiver is not connected, plug it into the connector in the electrical cabinet.
- ii) If your remote control is wireless, locate a part of the vehicle wall you can fit it to.
- jj) Check there is material in the hopper and load it if necessary. Check there are no foreign bodies in the hopper. Unbolt and open the hopper door. Place the bag of wool on the door, cut the bag open and empty the wool into the hopper. Make sure the plastic bag has been completely removed.

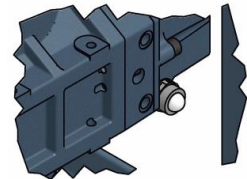

WARNING! For compliance with EU load-handling regulations, we recommend cutting the bags of wool in half before placing them on the door.

CAUTION! We recommend securing the bag cutting tool to the machine frame with a rope or chain, to prevent damage to the system if it accidentally falls onto the spindles.

- kk) Close the hopper door.
- ll) Check that there are sufficient hose sections to carry out the blowing process, and ensure they are firmly connected with their flanges.
- nn) Check the injection nozzle is in perfect working order.
- oo) Check the manual injection head valve is closed.
- pp) Check there is no material in the hose.

NOTE: At the end of the day's work, when you finish filling the last hole, make sure you empty out any material that may have accumulated in the hose and nozzle. To do this, blow the surplus material into the plastic bag supplied with the machine or a container suitable for this use.

Residual material could cause blockage when you begin work the next day.





- qq) Insert the key in the engine ignition in the electrical cabinet.
- Turn the ignition key clockwise to position 1. The red LED will light up.
 - Wait until the spark plug firing indicator light switches off.
 - Turn the ignition key clockwise again to position 2.
 - Make sure that all the indicator lights are off when the engine is running, and that only the engine protection indicator light remains on.

When 8 seconds have elapsed the blue “Ready” LED will come on to show that the machine is ready for the blower and mechanical transmissions to start up.



CAUTION! When the engine has started up, if everything is functioning correctly only the green engine protection indicator light should remain lit on the engine control panel. All the other indicator lights should be off. If everything is functioning correctly, the indicator light will remain on while the engine is running.

If any of the three major engine anomalies are detected – low oil pressure (), coolant temperature too high () or air filter obstructed () – the engine protection light will switch off and the indicator light for the anomaly in question will come on. If this indicator light remains on for 3 seconds, the engine will stop.

CAUTION! Do not rev the starter motor for more than 20 seconds continuously. If the engine does not start up, wait for 1 minute before repeating the manoeuvre. If the engine does not start up after two consecutive attempts, consult the engine service manual to find out the cause of the problem.



Before starting up the engine, check that all the safety guards are in place and carefully read all the technical and safety documentation in the engine service manual supplied with each machine. Special attention must be paid to this information in order to understand the operating of the engine and its conditions of use. Its purpose is to enhance user safety and prevent breakdowns caused by incorrect use.

Ensure the exhaust pipe is outside the vehicle cabin. Never work with the engine running in a closed space as inhalation of the exhaust gases could cause serious injury or even death.

- rr) Pick up the injection head, open the manual valve if it is not already open and insert the nozzle in the first hole for the blowing process.
If you are starting a new blowing process and need to make a new calibration, proceed as described on page 29 of this manual.



Service Manual

ss) The machine is now ready to begin the injection process and all that is required is to press the “AIR & FIBRE” button on the wired or wireless remote control, for the material to begin to flow to the nozzle.

NOTE: A red LED indicator light on the remote control lights up whenever any of the buttons is pressed.

If the remote control is not working and the LED does not come on, check the receiver is correctly plugged into the electrical cabinet connector. If it is, replace the battery. The battery should be replaced yearly.

If the LED comes on but the remote control does not work when the AIR ONLY or AIR & FIBRE buttons are pressed, check that the green LED or the yellow LED are lit in the electrical cabinet. If they are not, this means the receiver is not correctly receiving the signal from the remote control.

NOTE: For more information on the wall blowing process, read the installation and blowing guides provided by the material manufacturer.





DAILY SHUTDOWN PROCEDURE

- a) Press the **STOP** button on the wired or wireless remote control, then press the **AIR ONLY** button to start up the blower.

Point the nozzle into the bag supplied with the machine and discharge all the material remaining in the nozzle and hose into the bag.

NOTE: *When you have finished filling the last hole, make sure you empty out any material that may have accumulated in the hose and nozzle. To do this, blow the surplus material into the plastic bag supplied with the machine or a suitable container.*

Residual material could cause blockage when you begin work the next day.

- b) When you have finished emptying out the material, press the **STOP** button on the wired or wireless remote control and stop the engine by turning the key counter-clockwise to “0”.
- c) Cover the top of the hopper with a plastic or canvas sheet. This will prevent damp from entering the hopper overnight and all the physical properties of the material will remain intact until the next day.
- d) Whenever possible, always fill up the fuel tank at the end of the day, as this will prevent condensation from forming overnight.

Check the fuel level in the tank and fill it up with **DIESEL FUEL** if necessary. The capacity is approximately 29 litres. The **DIESEL FUEL** must comply with the characteristics and specifications indicated in the engine service manual. *Read the engine service manual.*

Ensure the shut-off valve for opening and closing the flow of fuel to the engine is open.

The tank has a capacity of 29 litres of **DIESEL FUEL**. With a full tank, the engine can run for approximately 12 hours.

It has an electronic level indicator and a visual level indicator. When the indicator light on the engine control panel comes on, this means that the amount of diesel fuel remaining in the tank is approximately 7 litres. This will allow the engine to run for around 3 hours.

NOTE *Purchase the fuel in small amounts and store it in suitable, clean containers.*

Clean fuel prevents the injectors from becoming obstructed.

Do not fill the fuel tank right up to the top. Leave some space for the fuel to expand.

When filling the tank, clean up any fuel spills immediately.

Never allow the tank to drain completely, to avoid having to bleed the air from the fuel system.

Diesel fuels complying with the specifications ASTM D-975 – 1D or 2D, EN590 or equivalent are suitable for use with this type of engine.

For more information, see the engine service manual.

WARNING! *Never store fuel in galvanised containers, as the fuel and the galvanized container would produce a chemical reaction and clot, which would quickly obstruct the filters or cause the injection pump and injectors to fail.*

WARNING! *Never add fuel while the engine is running or in a closed space, as this could result in inhalation of toxic gases.*



MAINTENANCE

For optimum machine performance, a series of daily and periodical maintenance operations need to be carried out.

WARNING! *Carrying out maintenance work with the machine plugged into the mains may give rise to very serious injury and even death. Never perform any maintenance unless you are sure the machine has been unplugged and the engine stopped.*



To prevent personal injury caused by incorrect handling of the raw materials and products used in the process, please carefully read the safety information provided by your supplier.



To prevent any damage caused by compressed air impact, do not open any connections or carry out any maintenance work on pressurised components until the pressure has been totally released.

Use suitable protection when carrying out machine operation and maintenance work and whenever you are in the machine's operating area. This includes, but is not limited to, wearing a face mask, protective goggles, safety gloves, safety footwear and safety clothing.

Some machine components become very hot and may cause burns. Do not handle or touch any hot parts of the unit until they have cooled down.



Carefully read all the technical and safety documentation included in the engine service manual.

To prevent serious injury (serious blows or amputations), do not work with the machine unless the safety guards have been duly installed on the moving parts. Ensure all the safety guards are correctly fitted back onto the machine again after finishing any repair or maintenance work.

Carefully read all the technical and safety documentation included in the blower service manual.



The waste generated on maintenance must be managed in accordance with the applicable regulations in each country.

Disconnect the machine from the electrical mains before carrying out any operations inside the electric console.

Electrical maintenance of the machine must only be carried out by a specialist technician.



Only use original NOVAQ spare parts. Use of non-original spares may cause the machine to malfunction.

The use of non-original spares will invalidate the HI-TECH SPRAY EQUIPMENT, S.A. guarantee.



PERIODICAL MAINTENANCE TABLE	DAILY	WEEKLY	AFTER 50 HOURS	EVERY 250 HOURS	EVERY YEAR	EVERY 500 HOURS	EVERY 1000 HOURS	EVERY 4000 HOURS	EVERY 5000 HOURS	EVERY 8,000 HOURS	WHEN INDICATOR LIGHT COMES ON
	Clean the radiator air suction filter	X									
Clean the radiator heat exchanger surface		X									
Clean the machine engine compartment air filters	X										
Clean the engine air filter											X
Clean the working surface around the machine	X										
Clean and inspect the objects in the hopper	X										
Clean pressure switch and manometer air filter		X									
Check the battery density	X										
Clean the battery terminals				X							
Clean the fuel tank							X				
Check the engine oil level	X										
First engine oil change			X								
Periodical engine oil change				X							
Change the oil filter					X						
Check the oil level in the blower sumps			X								
First blower sumps oil change (PAO)						X					
Change the oil in the blower sumps (PAO)				X						X	
Check the coolant level	X										
Change the coolant							X				
Check the cooling circuit connectors		X									
Clean the inside of the radiator								X			
Check the fuel level	X										
Check and drain the fuel filter water		X									
Change the fuel filter						X					
Replace the fuel pipes								X			
Oil the pinions, chains and gears		X									
Oil the bearing supports		X									
Check the hose and nozzle	X										



PERIODICAL MAINTENANCE TABLE	DAILY	WEEKLY	AFTER 50 HOURS	EVERY 250 HOURS	EVERY YEAR	EVERY 500 HOURS	EVERY 1000 HOURS	EVERY 4000 HOURS	EVERY 5000 HOURS	EVERY 10,000 HOURS	WHEN INDICATOR LIGHT COMES ON
	Replace the airlock rubber seals and bearings				X						
Check the high pressure triggering (350 mbar)				X							
Check the chain tightener tension				X							
Check for wear to the pinions and gears				X							
Check the blower belt tension				X							
Replace the blower belts						X					
Check the mechanical transmission belt tension				X							
Replace the mechanical transmission belt						X					
Check the additional alternator belt tension				X							
Replace the additional alternator belts						X					
Check the engine alternator belt tension				X							
Replace the engine alternator belt						X					
Partial engine inspection									X		
Engine overhaul										X	
Adjust the rocker arm valve tolerance						X					
Change the distribution belt								X			
Adjust and clean the injectors								X			
Replace the wireless remote control battery						X					
Replace vibration damper of the clutch						X					



a) Daily Maintenance

1. Cleaning the radiator air suction filter

Blast compressed air over the whole of the filter surface to remove any particles.

2. Cleaning the engine compartment guard air filters

Blast compressed air over all the filter surfaces to remove any particles.

3. Cleaning the working surface around the machine

Remove any material that may have accumulated around the machine, to prevent the blower, the engine air filter or the radiator from sucking in any particles that could damage their functioning.

4. Cleaning and inspecting objects in the hopper

At the end of the working day, we recommend emptying out any material remaining in the hopper, to prevent contamination from condensation from occurring overnight.

Check before starting up the machine each day that there are no foreign bodies in the hopper.

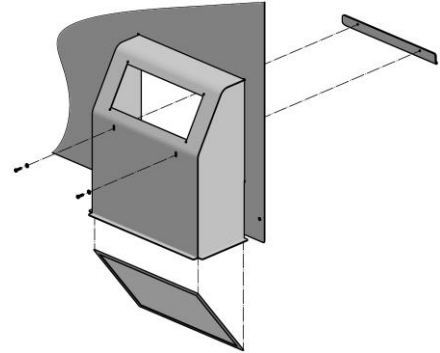

WARNING! Never put your hand inside the feed hopper unless it has been disconnected or the engine has been switched off.

5. Checking the battery density

Check the state of the battery visually each day. Visual inspection of the hydrometer in the battery cover will indicate one of three states:

- **Green dot:** State of charge 65% or over.
- **Black dot:** State of charge less than 65%. You should recharge the battery immediately.
- **White dot:** Electrolyte low. The reason for this is that the battery has been overcharged with excessive voltage for a long period. The battery will need replacing.

Check the alternator and engine voltage regulator.



6. Checking the engine oil level

Check the level each day before starting up the machine, as a low oil level could cause very serious damage to the engine. *Read the engine service manual.*

7. Checking the coolant level

Check the level each day before starting up the machine, as a low coolant level could cause very serious damage to the engine. *Read the engine service manual.*

8. Checking the fuel level

Check the fuel level each day before starting up the machine, to avoid having to bleed the air from the fuel system if it runs out.

9. Checking the hose and nozzle

Check for any wear to the hose and nozzle each day and replace them if necessary.

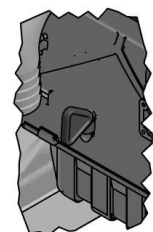



b) Weekly Maintenance

10. Cleaning the radiator heat exchanger surface

To prevent the radiator heat exchanger surface from becoming obstructed, blast compressed air over the entire surface or clean it with a brush soaked in diesel fuel.

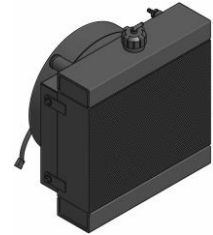

11. Cleaning the pressure switch and manometer air filter

The filter has an interior mesh to prevent solid particles from entering the pressure switch and manometer and causing malfunctioning.

Completely unscrew the cap to remove the mesh and clean it with compressed air or replace it if necessary.

12. Checking the cooling circuit connectors

Remove the guards and visually inspect for any leaks. If you observe any leakage, replace the connectors with new ones.

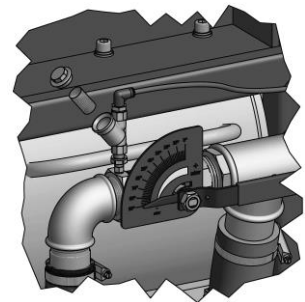

13. Checking and draining the fuel filter water

Unscrew the nut on the bottom of the filter to drain off any water that has accumulated. *Read the engine service manual.*

14. Oiling the pinions, chains and gears

Remove the front guard from the machine. Soak a brush in lubrication grease with a lithium and mineral oil base and grease all the components thoroughly.

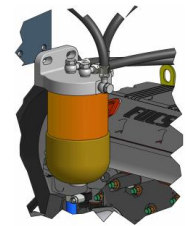

WARNING! Ensure all the safety guards are correctly fitted back onto the machine again after finishing any repair or maintenance work.

15. Oiling the bearing supports

Lubrication is essential for the bearings to function correctly. Most bearing malfunctioning is caused by lack of lubrication.

The lubricant also ensures protection against rust and external pollution. Remove the front and side guards from the machine.

To facilitate the oiling process, all the bearing supports are equipped with an oiler. Use a standard grease gun and its accessories for this purpose.

There are a total of 12 bearing supports requiring oiling.

Use a lithium and mineral oil-based lubricating grease.

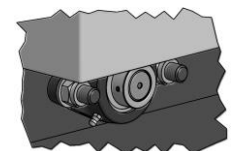

WARNING! Ensure all the safety guards are correctly fitted back onto the machine again after finishing any repair or maintenance work.



c) Maintenance after 50 hours

16. First engine oil change

To change the oil, follow the instructions provided in the engine service manual supplied with the machine.

Remove the left side guard for ease of operation.

NOTE: When refilling is required, remember that the oil must comply with the characteristics and specifications indicated in the engine service manual. Read the engine service manual. Oil filling and level checking must be done on flat ground. Change the oil again after the first 50 hours of engine functioning.

WARNING! Never add oil while the engine is running.

WARNING! Ensure all the safety guards are correctly fitted back onto the machine again after finishing any repair or maintenance work.

17. Checking the oil level in the blower sumps

Check the oil level in the two oil sumps visually. Make sure the colour is correct.

In theory, the oil should be changed after 8,000-10,000 hours of machine operation. The visual inspection is simply to ensure there are no fissures in the sumps caused by any knocks or incorrect handling on transport or installation.

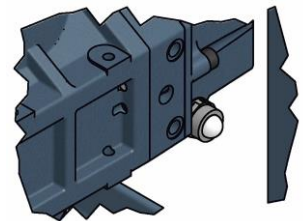

d) Maintenance every 250 hours

18. Cleaning the battery terminals

Remove the battery cables (remove the negative cable first). Clean the battery terminals (+ and -) and the flanges, using acid-free, acid-resistant grease. When you have fitted the flanges, ensure they make good contact.

19. Periodical engine oil change

Follow the instructions given in point 16 of this section.

20. Replacing the airlock rubber seals and bearings

HI-TECH recommends that machine users always have a totally assembled spare airlock available to replace the airlock removed for maintenance.

Having two airlocks available will limit machine downtime.

It should not take any longer than 15 minutes to replace the airlock.

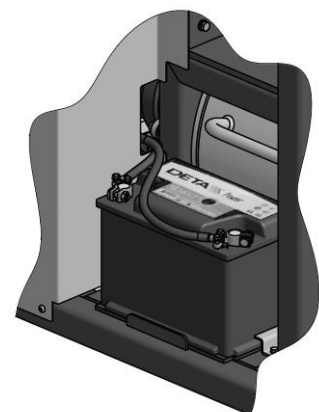



The procedure is as follows:

- 1) Loosen the fixing flange and disconnect the blower pressure hose from the inlet connector.
- 2) Loosen the two upper knobs and totally unscrew the 2 lower knobs to remove the front guard from the machine.
- 3) Loosen the fixing flange and disconnect the blower pressure hose from the outlet connector.
- 4) Loosen the tensor bolt using an 8 mm Allen key, securing the bracket with a spanner or wrench. Turn the chain counter-clockwise to remove it.

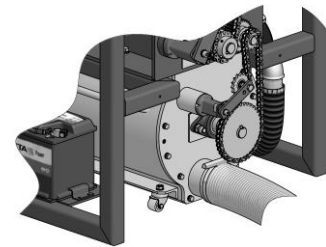
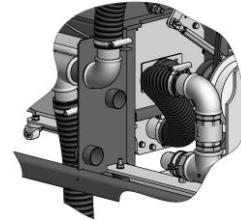
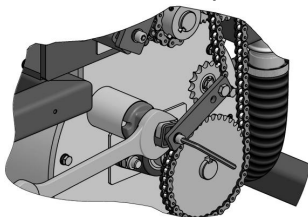

- 5) Remove the quick-closing coupling from the chain using pliers, and then remove the chain.
- 6) Unscrew the 6 hex screws holding the airlock to the structure using a 19 mm open-ended spanner or ratchet wrench. Alternatively, unscrew the screws progressively so as not to force them.
- 7) The airlock will now be resting on the ground with the 4 wheels. Pick it up by its handles and pull it out of the machine.
- 8) Replace the airlock with another one that has undergone maintenance. Fit the new airlock into its assembly position on the machine, sliding it along the ground.
- 9) Fit the 6 screws, alternatively turning them clockwise to fix it to the structure.
- 10) Fit the chain and tensor back in their original position. You will need an Allen key and a spanner or wrench to fit the tensor.
- 11) Fit the hose to the blower pressure outlet connector. Ensure the flange is firmly tightened.
- 12) Fit the guard in place, centring it on the two upper knobs. Fit the two lower knobs in place and tighten them. Tighten the upper knobs.
- 13) Fit the hose to the blower pressure inlet connector. Ensure the flange is firmly tightened.
- 14) The machine is now ready to work again. Changing the airlock should not have taken any longer than 15 minutes.

For easier replacement of the rubber seals and bushings on the replaced airlock, take it to your premises and proceed as follows:

- 1) Place the airlock on a firm, secure surface where you can easily work standing up. Attach it to the workbench with clamps.
- 2) Use an Allen key to unscrew the set screw from the two bearing support eccentrics and release the shaft.
- 3) Unscrew the bearing support nuts on the front cover using a 22 mm socket wrench.
- 4) Remove the key from the shaft and take out the bearing support shaft and the plate.



- 5) Use a 13 mm hex wrench to unscrew the bolts holding the front cover to the airlock body (there are a total of 11 bolts).
- 6) Remove the cover from the shaft with the two locating pins. To do this, carefully knock the cover from the inside outwards with a plastic mallet.
- 7) Remove the bronze bushing from the front cover, carefully knocking it with a plastic mallet.
- 8) Check for any wear to the inside of the two covers caused by friction. If they are significantly worn, replace the covers.
- 9) Fit the new bushing into the front cover, using a plastic mallet to knock it into its housing.
- 10) Fit the removal tool onto the shaft. Position the two threaded rods in the key groove and tighten the two threaded rods against the groove, taking care not to damage the groove or the shaft.
- 11) Check for any wear to the inside of the two covers caused by friction. If they are significantly worn, replace the covers.
- 12) Take hold of the removal tool arms with both hands, turn it counter-clockwise in one sudden movement and take the turbine out of its casing.
- 13) Loosen the two threaded rods with an Allen key and take the removal tool off the shaft.
- 14) Unscrew the two bearing support nuts on the rear cover using a 22 mm socket wrench, and take out the cover support and plate.
- 15) Remove the bronze bushing from the rear cover, carefully knocking it out from the inside of the cover with a plastic mallet.
- 16) Fit the new bushing into the rear cover, using a plastic mallet to knock it into its housing.
- 17) Fix the bearing support and the plate on the threaded rods on the rear cover. Fit the two washers and the two nuts in place and tighten them with a 22 mm spanner.
- 18) Replace all the rubber seals on the blades, one by one. Unscrew the 6 bolts on each blade using a 10 mm spanner and take out the blade and the rubber seal. Then replace the rubber seal, fit the blade back in place and replace the 6 bolts, turning them clockwise. Take care on fitting the rubber seal and the blade on the right hand side (seen from the longest side of the shaft).
- 19) Oil the friction surface of the rubber seals using a lithium and mineral oil-based lubricating grease.
- 20) Fit the removal tool to the shaft again, tightening the two threaded rods with an Allen key.
- 21) Insert the turbine into the airlock casing, turning the rubber seals counter-clockwise, and insert the shaft in the rear cover bushing, ensuring it is inserted axially as far as it will go against the bushing. Make sure the seal bases close radially over the bushing.
- 22) Loosen the two threaded rods with an Allen key and take the removal tool off the shaft.

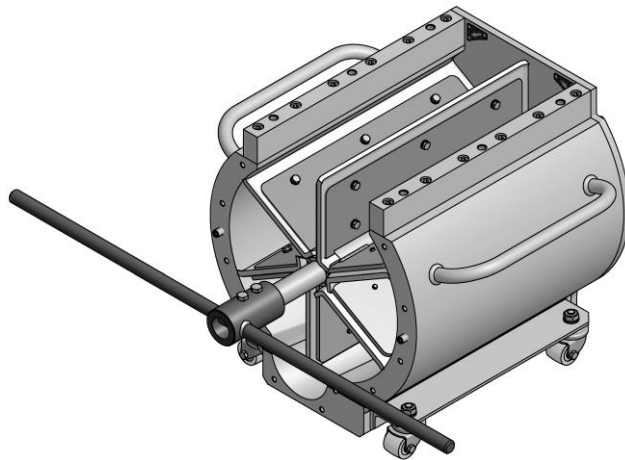



- 23) Insert the front cover onto the turbine shaft, centring it on the shaft and locating pins. Make sure the seal bases close radially over the bushing.
- 24) Use a 13 mm hex wrench to alternately screw the bolts holding the front cover to the airlock body (there are a total of 11 bolts). Make sure that as you tighten the bolts, the sides of the seals all adapt to the same degree and in the right direction (according to the rotation direction) on the axial surfaces of the front and rear airlock covers.
- 25) Fix the bearing support and the plate on the threaded rods on the front cover. Fit the two washers and the two nuts in place and tighten them with a 22 mm spanner.
- 26) Use an Allen key to screw the set screw onto the two bearing support eccentrics, to fix the turbine to the supports.

21. Checking the high pressure triggering system (350 mbar)

Open the electrical cabinet lid to view the pressure switch display.

Create overpressure in the injection head by closing the manual valve with the blower running.

This is to check that the default safety pressure remains correctly calibrated. If it is not, check that the filter and the tube conveying the air to the pressure switch are not obstructed.

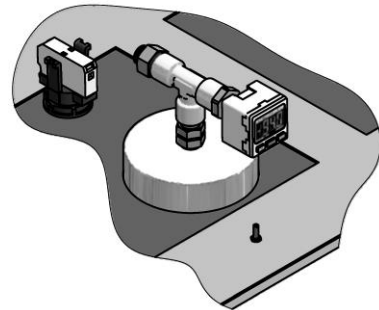

22. Checking the chain tightener tension

Remove the front guard from the machine. Press the middle of the chain with your thumb. The flexure should be less than 1 cm. If it is greater than 1.0 cm, tighten the chain.

Use an Allen key to unscrew the tensor bolt, and turn the tensor arm clockwise with a spanner. Then tighten the Allen bolt again.

Replace the chains if they show any signs of premature wear.

Fit the guard back onto the machine.

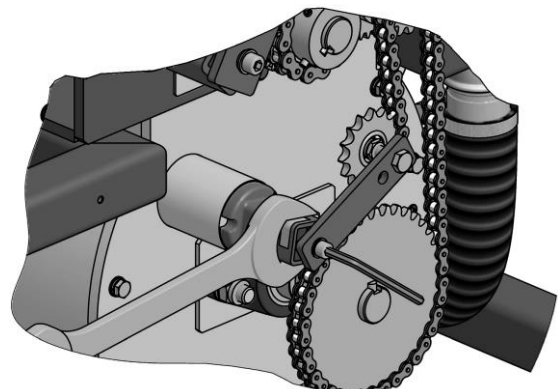

23. Checking for wear to the pinions and gears

Remove the front guard from the machine.

Check for any wear to the pinions and gears. If they show signs of wear, replace them.

Fit the guard back onto the machine.

24. Checking the blower belt tension

Remove the left side guard from the machine.

Press the middle of the belts with your thumb. The flexure should be less than 1.5 cm. If it is greater than 1.5 cm, tighten the belts.

Loosen the nut using a 19 mm socket wrench and turn the bolt clockwise using another 19 mm spanner. Tighten the nut.

Fit the guard back onto the machine.

Replace the belts if they show any signs of premature wear.



25. Checking the mechanical transmission belt tension

Remove the left side guard from the machine.
Press the middle of the belt with your thumb. The flexure should be less than 1.5 cm. If it is greater than 1.5 cm, tighten the belt.
Using a 19 mm socket wrench, turn the hex bolt counter-clockwise to tighten it further.
Fit the guard back onto the machine.
Replace the belt if it shows any signs of premature wear.

26. Checking the additional alternator belt tension

Remove the left side guard from the machine.
Press the middle of the belts with your thumb. The flexure should be less than 1.5 cm. If it is greater than 1.5 cm, tighten the belts.
Loosen the two nuts on the support using a 19 mm socket wrench and push the support upwards. Then tighten the nuts again.
Fit the guard back onto the machine.
Replace the belts if they show any signs of premature wear.

e) Annual Maintenance

27. Changing the oil filter

Remove the left side guard from the machine.
Follow the instructions given in the engine service manual supplied with the machine.
Fit the guard back onto the machine.

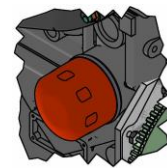

28. Changing the wireless remote control battery

Remove the rear cover from the remote control and replace the battery.



f) Maintenance every 500 hours

29. Changing the fuel filter

Remove the left, right and rear guards from the machine.
Follow the instructions given in the engine service manual supplied with the machine.
Fit the guards back onto the machine.

30. Replacing the blower belts

Remove the left side guard from the machine.
Loosen the tensor nut using a 19 mm socket wrench and turn the bolt counter-clockwise using another 19 mm spanner to loosen the belts.
When the belts have been loosened, remove them and replace them with two new ones.
Tighten them again by turning the bolt clockwise, and tighten the nut.
Fit the guard back onto the machine.

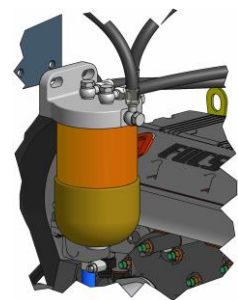

31. Replacing the mechanical transmission belt

Remove the left side guard from the machine.
Using a 19 mm socket wrench, turn the tensor hex bolt clockwise to loosen the belts.
When it has been loosened, replace it with a new belt.



Tighten the belts again by turning the hex bolt counter-clockwise.

Fit the guard back onto the machine.

32. Replacing the additional alternator belts

Remove the left side guard from the machine.

Loosen the two nuts in the support using a 19 mm socket wrench and push the support downwards to loosen it.

When the belts have been loosened, remove them and replace them with two new ones.

Tighten them again by pushing the support upwards and tighten the bolts.

Fit the guard back onto the machine.

33. Replacing the engine alternator belt

Remove the left side guard from the machine.

Follow the instructions given in the engine service manual supplied with the machine.

Fit the guard back onto the machine.

34. Adjusting the rocker arm valve tolerance

Remove the left, right and rear guards from the machine.

Follow the instructions given in the engine service manual supplied with the machine.

Fit the guards back onto the machine.

g) Maintenance every 1,000 hours

35. Cleaning the fuel tank

Disconnect all the tubes from the tank.

Disconnect the electronic level indicator connector.

Unscrew the bolts holding the electronic level indicator to the tank and remove the level indicator.

Unscrew the 4 bolts holding the tank to the frame. Two people will be needed to do this. Remove the tank.

Place the tank in a container or in a suitable location for cleaning and waste collection.

Unscrew the filler cap.

Pour some clean diesel fuel into a Karcher high pressure cleaner or similar, suitable for cleaning with diesel fuel.

Insert the nozzle into the hole in the cap and spray the diesel fuel at high pressure, pointing the nozzle at the walls and base of the tank.

Drain the diesel fuel from the tank into a suitable container.

Put the tank back onto the frame. Connect the tubes and the electronic level indicator, and fit the cap back in place.



CAUTION! The waste generated on maintenance must be managed in accordance with the applicable regulations in each country.



36. Changing the coolant

Remove the left, right and rear guards from the machine.

Follow the instructions given in the engine service manual supplied with the machine.
The circuit has a total capacity of approximately 7 litres.

Fit the guards back onto the machine.

h) Maintenance every 4,000 hours

37. Cleaning the inside of the radiator

Remove the left, right and rear guards from the machine.

Follow the instructions given in the engine service manual supplied with the machine.

Fit the guards back onto the machine.

38. Replacing the fuel pipes

Remove the left, right and rear guards from the machine.

Follow the instructions given in the engine service manual supplied with the machine.

Fit the guards back onto the machine.

i) Maintenance every 5,000 hours

39. Partial engine inspection

Follow the instructions given in the engine service manual supplied with the machine.

j) Maintenance every 10,000 hours

40. Changing the oil in the blower sumps

Remove the right side guard.

Follow the instructions given in the engine service manual supplied with the machine.

Fit the guard back onto the machine.

41. Engine overhaul

Follow the instructions given in the engine service manual supplied with the machine.

k) Maintenance when the engine control panel alarm is triggered

42. Cleaning the air filter

Remove the right side guard.

Follow the instructions given in the engine service manual supplied with the machine.

Fit the guard back onto the machine.



I) Maintenance as required

43. Replacing the electrical cabinet

- Disconnect the multi connector on the underside of the cabinet.
- Disconnect the manometer and pressure switch air tube on the connector on the underside of the cabinet.
- Open the cabinet door and disconnect 2 faston connectors. Then disconnect 2 connectors from the engine control panel.
- Insert the 2 control panel connectors through the bushing on the underside of the cabinet and take them out of the cabinet.
- Use an Allen key to unscrew the 4 bolts holding the electrical cabinet to the machine frame, and carefully remove the cabinet. To do this you will need help from another person, to hold the cabinet while you unscrew the bolts.
- Fit the new cabinet onto the machine frame, open the door and screw in the 4 bolts holding the cabinet to the machine frame using an Allen key. To do this you will need help from another person, to hold the cabinet while you screw in the bolts.
- Thread the 2 engine control panel connectors through the bushing on the underside of the cabinet.

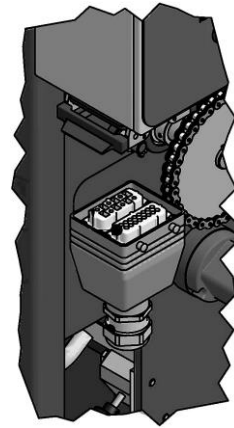



- Connect the manometer and pressure switch air tube on the connector on the underside of the cabinet.
- Connect the 2 control panel connectors and the 2 faston connectors.
- Close the cabinet door.
- Connect the multi connector on the underside of the cabinet.

44. Replacing the conveyor spindles

- Use a 13 mm spanner or socket wrench to unscrew both ends of the bolt holding the spindle to the bearing support shaft.
- Hold the two ends of the spindle in place with a rope. Secure the other end of the rope to a fixed anchor point on the vehicle roof or to the forks of a forklift truck. Tighten the rope sufficiently so that it will hold the spindle when it is released. On tightening the rope, take care not to exert pressure on the spindle.
- Remove the front guard from the machine.
- Loosen the upper chain tensor bolt using an 8 mm Allen key, securing the bracket with a spanner or wrench. Turn the chain counter-clockwise to remove it.
This step will not be necessary if you only wish to replace the spindle on the left side.
- If you only wish to replace the left spindle, remove the parallel chain. If you wish to replace the right spindle or both spindles, remove both chains.
- Remove the chain, using pliers to take out the quick-closing coupling.
- Unscrew the bearing support nuts on the sides of the hopper using a 22 mm socket wrench.
- Remove the bearing support from the rear of the machine (fuel tank side), together with the shaft inside the spindle.
- Remove the bearing support, the pinion(s) and the shaft inside the spindle from the front of the machine (electric console side).
- The spindle will now be hanging from the rope. Pull it upwards to remove it from the hopper. If a forklift truck is being used, another person should ensure it does not become unbalanced and knock against the hopper. If there is no mechanical system available, two people will be needed to take it out of the hopper. Its weight is 20 kg.

45. Replacing the lower agitator spindle

- Remove the two upper spindles as described in point 44.
- Use a 13 mm spanner or socket wrench to unscrew both ends of the bolt holding the spindle to the bearing support shaft.
- Hold the two ends of the spindle in place with a rope. Secure the other end of the rope to a fixed anchor point on the vehicle roof or to the forks of a forklift truck. Tighten the rope sufficiently so that it will hold the spindle when it is released. On tightening the rope, take care not to exert pressure on the spindle.
- Remove the front guard from the machine.
- Loosen the bolts on the two chain tensors using an 8 mm Allen key, securing the brackets with a spanner or wrench. Turn them counter-clockwise to remove them from the chains.
- Remove the two chains, taking out the quick-closing couplings with pliers.
- Unscrew the bearing support nuts on the sides of the machine using a 22 mm socket wrench.



- Take the bearing support out of the hopper, together with the shaft inside the spindle.
- Remove the bearing support, the two pinions and the shaft inside the spindle from the front of the machine.
- The spindle will now be hanging from the rope. Pull it upwards to remove it from the hopper. If a forklift truck is being used, another person should ensure it does not become unbalanced and knock against the hopper. If there is no mechanical system available, take it out of the hopper manually. Its weight is 4.5 kg.

46. Replacing the turbine feed shafts

- Remove the front guard from the machine.
- Loosen the lower chain tensor bolt and the central chain tensor bolt using an 8 mm Allen key, securing the brackets with a spanner or wrench. Turn them counter-clockwise to remove them from the chain.
- Remove the two lower chains, using pliers to take out the quick-closing couplings.
- Unscrew the bit from the eccentrics holding the shafts to the two bearing supports inside the machine (engine compartment).
- Unscrew the bearing support nuts on the front of the machine (electric console side) using a 22 mm socket wrench.
- Firmly grasp the cover and pull the two bearing supports, the cover and the two shafts towards you. The weight of the whole unit is 12 kg.



TROUBLESHOOTING

The **novaG-fill 60/novaG-fill 60-G** machine is highly reliable and designed to withstand tough working conditions, providing it is properly used and receives correct maintenance. This section contains information on any problems that could prevent the machine from operating correctly. This information will serve as a guideline for detecting and solving most of these problems without needing to call your authorised dealer or HI-TECH technical assistance service for help. In any case, please feel free to contact the HI-TECH SPRAY EQUIPMENT, S.A. technical assistance service, where a team of qualified technicians will provide help and advice whenever you need it.



To prevent personal injury caused by incorrect handling of the raw materials and products used in the process, please carefully read the safety information provided by your supplier.



To prevent any damage caused by compressed air impact, do not open any connections or carry out any maintenance work on pressurised components until the pressure has been totally released.

Use suitable protection when carrying out machine operation and maintenance work and whenever you are in the machine's operating area. This includes, but is not limited to, wearing a face mask, protective goggles, safety gloves, safety footwear and safety clothing.

Some machine components become very hot and may cause burns. Do not handle or touch any hot parts of the unit until they have cooled down.

Carefully read all the technical and safety documentation included in the engine service manual.



To prevent serious injury (serious blows or amputations), do not work with the machine unless the safety guards have been duly installed on the moving parts. Ensure all the safety guards are correctly fitted back onto the machine again after finishing any repair or maintenance work.

Carefully read all the technical and safety documentation included in the blower service manual.

The waste generated on maintenance must be managed in accordance with the applicable regulations in each country.



Disconnect the machine from the electrical mains before carrying out any operations inside the electric console.

Electrical maintenance of the machine must only be carried out by a specialist technician.

Only use original NOVAG spare parts. Use of non-original spares may cause the machine to malfunction.



The use of non-original spares will invalidate the HI-TECH SPRAY EQUIPMENT, S.A. guarantee.



Problem	Cause	Solution
1. The engine does not start	Insufficient fuel	1.1 Fill the tank
	Fuel tap closed	Open the fuel tap
	Battery defective or run down	1.2 Check the battery charge and engine alternator
	Fuel filter obstructed	1.3 Check the filter, drain off the water or replace it
	Air in the fuel supply system	1.4 Check it and bleed out the air
	An emergency button has been pressed	1.5 Check and deactivate it
	1.6 Check what indicator lights on the control panel are on, and/or consult the engine service manual	
2. Engine overheating	The electric fan motor is not working properly	2.1 Check the state of the operating fuse F4 (3A) on the electric console Replace it if it has blown
	The thermostat is not working	2.2 Check the state of the thermostat B1 Check that the voltage between connections 107 and M is 12 volts If it is not 12 volts, replace the thermostat
	The power fuse has blown	2.3 Check the state of the power fuse F1 (20 Amp) Replace it if it has blown
	Relay R4 is not working	2.4 Check that the voltage between connections 102 and M is 12 volts If it is not 12 volts, replace the relay
3. With the engine running The blue "READY" LED does not switch on	The hopper door is open	3.1 Close the hopper door
	The hopper door is closed The power fuse has blown	3.2 Check the state of the operating fuse F4 (3A) on the electric console Replace it if it has blown
	The hopper door is closed The limit switch B4 is not working	3.3 Check the state of the limit switch B4 Replace it if it is not working



Problem	Cause	Solution
3. With the engine running The blue “READY” LED does not switch on	The hopper door is closed The processor is not working	3.4 Check the state of the processor If a green light is on, it is OK If a red light is on, the memory module is faulty Replace the memory module If there is no light on, the processor is faulty Replace the processor
	The hopper door is closed The green light on the processor is on The blue LED is not working	3.5 Replace the blue LED
4. With the engine running The red remote control indicator LED does not light up	There is no remote control connected	4.1 Connect a remote control to the electric console connector
	There is a remote control connected to the electric console connector The fuse F4 has blown	4.2 Check the state of the operating fuse F4 (3A) on the electric console Replace it if it has blown
	The remote control is connected The electrical connection, the connector or the button has failed	4.3 Check that the electrical connection from the electric console connector to the red button on the remote control is in good working order Replace or repair the element that is not working properly: the cable, the connector or the red button S7
	The wireless receiver is connected The receiver connector is faulty or badly connected	4.4 Check the wireless receiver connector Replace it if it is not working
	The wireless receiver is connected The battery has run down	4.5 Check whether the red LED on the remote control lights up when any of the 3 buttons on the control are pressed If it does not light up, change the battery
	The wireless receiver is connected The receiver is not in the correct location	4.6 If the remote control is not working and its red LED does not light up when any of the buttons are pressed, change the location of the receiver in the vehicle



Problem	Cause	Solution
5. With the engine running and the red LED on The yellow remote control indicator LED does not light up	The remote control is connected and it does not light up when the AIR & FIBRE button is pressed The electrical connection, the connector or the button has failed	5.1 Check that the electrical connection from the electric console connector to the red button on the remote control is in good working order Replace or repair anything that is not working properly: the cable, the connector or the red button S6
	The wireless receiver is connected The receiver connector is faulty or badly connected	5.2 Check the wireless receiver connector Replace it if it is not working
	The wireless receiver is connected The battery has run down	5.3 Check whether the red LED on the remote control lights up when the AIR & FIBRE button on the remote control is pressed If it does not light up, change the battery
	The wireless receiver is connected The receiver is not in the correct location	5.4 If the remote control is not working and its red LED does not light up when the AIR & FIBRE button is pressed, change the location of the receiver in the vehicle
	The wireless receiver is connected The transmitter is not working	5.5 If the remote control is not working and its red LED does not light up when the AIR & FIBRE button is pressed, replace the transmitter
6. With the engine running and the red LED on The green remote control indicator LED does not light up	The remote control is connected and it does not light up when the AIR ONLY button is pressed The electrical connection, the connector or the button has failed	6.1 Check that the electrical connection from the electric console connector to the red button on the remote control is in good working order Replace or repair the element that is not working properly: the cable, the connector or the red button S5
	The wireless receiver is connected The receiver connector is faulty or badly connected	6.2 Check the wireless receiver connector Replace it if it is not working
	The wireless receiver is connected The battery has run down	6.3 Check whether the red LED on the remote control lights up when the AIR ONLY button on the remote control is pressed If it does not light up, change the battery



Problem	Cause	Solution
<p>6. With the engine running and the red LED on</p> <p>The green remote control indicator LED does not light up</p>	<p>The wireless receiver is connected</p> <p>The receiver is not in the correct location</p>	<p>6.4 If the remote control is not working and its red LED does not light up when the AIR ONLY button is pressed, change the location of the receiver in the vehicle</p>
	<p>The wireless receiver is connected</p> <p>The transmitter is not working</p>	<p>6.5 If the remote control is not working and its red LED does not light up when the AIR ONLY button is pressed, replace the transmitter</p>
<p>7. With the engine running and the high pressure control selector switch not lit when it is turned to ON</p> <p>When there is overpressure in the system (350 mbar) the two clutches are not released</p>	<p>The pressure switch B2 is not working</p>	<p>7.1 Check the pressure switch</p> <p>Replace it if it is not working</p>
<p>8. With the engine running and the blue “READY” LED on</p> <p>The blower does not start</p>	<p>The blower clutch fuse F2 (6A) has blown</p>	<p>8.1 Check point 6 of the troubleshooting section. If everything is OK, replace the fuse F2 (6A)</p>
	<p>Relay V1 is not working</p>	<p>8.2 Check point 6 of the troubleshooting section to check whether everything is OK</p> <p>If the relay LED inside the console is lit, check whether everything is OK</p> <p>If it is not lit, replace relay V1</p>
	<p>The clutch electrical connection is faulty</p>	<p>8.3 Check point 6 of the troubleshooting section to check whether everything is OK</p> <p>Check whether everything is OK in the clutch electrical connection</p>
	<p>Transmission belts broken</p>	<p>8.4 Replace the belts</p>
	<p>The material is obstructing the turbine</p>	<p>Remove the cover and remove the obstruction from the turbine</p>
	<p>The material is obstructing the hose or nozzle</p>	<p>Find and remove the hose or nozzle obstruction</p>



Problem	Cause	Solution
<p>9. With the engine running and the blue “READY” LED lit</p> <p>The mechanical transmissions do not start</p>	The timer is not working correctly	<p>9.1 Check point 5 of the troubleshooting section to check whether everything is OK</p> <p>If everything is OK, check that the scales on the timer inside the electric console are working correctly</p> <p>The time unit on the upper scale should be 1 second</p> <p>The central scale should be between numbers 2 and 7</p> <p>The lower scale should be in position A</p> <p>When the timer is activated the green LED lights up. When the selected time has elapsed, the orange LED comes on and then switches off again. All the LEDs should be off at this stage. Check it is functioning correctly. If not, replace the timer</p>
	The transmission clutch fuse F3 (6A) has blown	9.2 Check point 5 of the troubleshooting section. If everything is OK, replace the fuse F3 (6A)
	Relay V2 is not working	<p>9.3 Check point 5 of the troubleshooting section to check whether everything is OK</p> <p>If the relay LED inside the console is lit, check whether everything is OK</p> <p>If it is not lit, replace relay V2</p>
	The clutch electrical connection is faulty	<p>9.4 Check point 5 of the troubleshooting section to check whether everything is OK</p> <p>Check whether everything is OK at the clutch electrical connection</p>
	Transmission belt broken	9.5 Replace the belt
	One of the transmission belts has broken	9.6 Replace the chain
	Gear broken	9.7 Replace the gear
	Pinion broken	9.8 Check which pinion has broken and replace it



CONTENTS

Guarantee	2
Safety and Handling	3
Main Characteristics	6
Technical Specifications	7
MACHINE	7
Progressive discharge AIRLOCK	7
THREE LOBE POSITIVE DISPLACEMENT BLOWER	7
LOMBARDINI LDW 1003 DIESEL ENGINE	8
ALTERNATOR (MODEL novaG-fill 60-G ONLY)	8
Description of Main Components	9
1. Hopper	10
2. Wool Loading Door	10
3. Conveyor Spindles	10
4. Agitator Spindles	10
5. Turbine Feed Shafts	10
6. Airlock	10
7. Adjustable Gates	11
8. Discharge Valve	11
9. Lower Manometer	11
10. Manometer Filter	11
11. Blower Air Suction Nozzle	11
12. Engine Air Suction Nozzle	11
13. Blower	12
14. Swinging Reducer	12
15. Blower Clutch	12
16. Mechanical Transmission Clutch	12
17. Radiator	12
18. Thermostat	13
19. Expansion Tank	13
20. Fuel Tank	13
21. Fuel Tank Electric Level Indicator	14
22. Fuel Tank Visual Level Indicator	14
23. Fuel Filter	14
24. Engine Oil Filter	14
25. Engine Oil Level	15
26. Engine Air Filter	15
27. Auxiliary Alternator (model novaG fill-60-G only)	15
28. Engine	15
29. Battery	15
30. Exhaust Pipe	16
Electrical Cabinet	16
1. Emergency Buttons	16
2. Partial Injection Time Counter	16
3. RESET Button	16
4. Total Airlock Functioning Time Counter	17



Service Manual

5.	High Pressure Control Selector _____	17
6.	Manometer _____	17
7.	Remote Control Connector _____	17
8.	Auxiliary Connector _____	17
9.	LED indicators _____	17
10.	LED Ready _____	17
11.	Multi Connector _____	17
12.	Engine Control Panel _____	18
13.	Wireless Remote Control _____	20
15.	Safety Pressure Switch _____	21
16.	Timer _____	22
17.	Auxiliary power (optional) _____	22
Before Start-Up _____		22
Installation in the Vehicle _____		24
Initial Start-Up _____		25
Calibration _____		29
Calibration Templates _____		31
Daily Start-Up Procedure _____		32
Daily Shutdown Procedure _____		36
Maintenance _____		37
Troubleshooting _____		52
Contents _____		58