

Service & Parts Manual

Insulated Product Hoses

Issue 1.2 - 28/04/2022
Ref. NR-00043-ENG

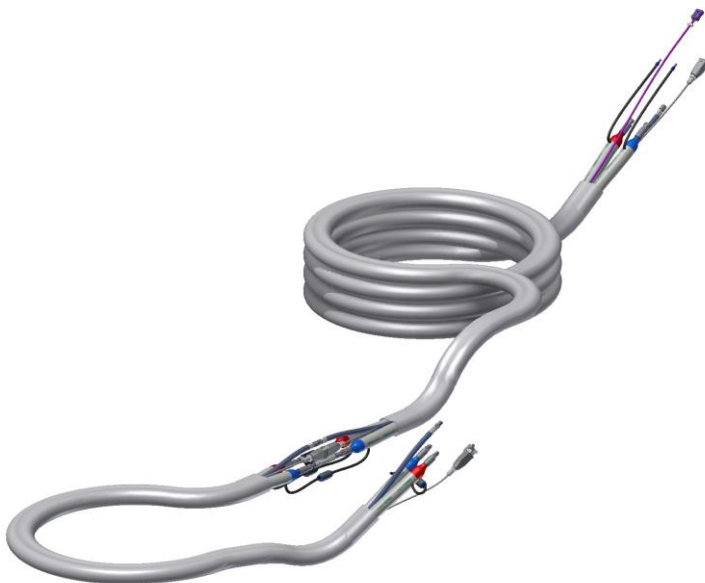

Before installing and operating the Unit, carefully read the technical and safety documentation in this manual. Special attention should be paid to the information in order to know and understand the handling and conditions of use of the Unit. All of the information is aimed at enhancing User Safety and avoiding possible faults due to incorrect use of the Unit.



WARRANTY

HI-TECH SPRAY EQUIPMENT, S. A. (hereinafter "HI-TECH") grants this Guarantee limited to the original purchaser (hereinafter "Client") for the equipment and the original accessories delivered with the equipment (hereinafter "Product") against any fault in design, materials or manufacture of the Product at the time of the first purchase by the users and for a period of two (2) years there from.

If during the guarantee period and under normal conditions of use, the Product should fail to work correctly due to defects of design, material or manufacture, the authorised distributor of the country where the HI-TECH Product or technical assistance service has been purchased shall repair or replace the Product in accordance with what is established in the following

CONDITIONS

- a) The validity of this guarantee will be subject to the presentation of the original invoice issued by the HI-TECH authorised distributor for the sale of the Product along with the Product handed over for repair or replacement, which must show the date of purchase and the serial number. HI-TECH reserves the right to refuse to give the guarantee service when the indicated data fail to appear on the invoice or have been modified after the purchase of the Product.
- b) The repaired or replaced Product will continue to maintain the original guarantee for the time remaining until the end of the guarantee or for three (3) months from the repair date, if the remaining period of the original guarantee were shorter.
- c) This guarantee will not be applied to the faults in the Product caused by its faulty installation, the natural wear and tear of the components, any use other than that considered normal for this Product or which should fail to strictly comply with the instructions of use provided by HI-TECH; due to accident, carelessness, adjustments, alterations or modifications of the Product not authorised by HI-TECH or due to the use of accessories, heating devices, pumping equipment and/or dispensers that have not been approved or manufactured by HI-TECH.
- d) The guarantee applicable to the components and accessories forming part of the Product and which have not been made by HI-TECH will be limited to the guarantee offered by the original manufacturer thereof.

HI-TECH WILL NOT RECOGNISE ANY EXPRESS ORAL OR WRITTEN GUARANTEES OTHER THAN THIS PRINTED LIMITED GUARANTEE. ALL IMPLICIT GUARANTEES, INCLUDING, WITHOUT LIMIT, ADAPTATION FOR A SPECIFIC USE, ARE SUBJECT TO THE DURATION OF THIS WRITTEN GUARANTEE. HI-TECH DOES NOT ASSUME ANY KIND OF COMMITMENT OR RESPONSIBILITY FOR ALL POSSIBLE DAMAGE OR EXPENSE CAUSED BY FAULTS IN THE OUTPUT OF THE PRODUCT, ITS WORKING OR THE DISPENSING OF MATERIAL THROUGH THE PRODUCT, INCLUDING, WITHOUT LIMITATION, ALL EXPENSES CAUSED BY DAMAGE TO PEOPLE OR PROPERTY. EQUALLY, HI-TECH WILL IN NO CASE ACCEPT LIABILITY FOR THE LOSS OF SPECULATIVE PROFITS OR COMMERCIAL LOSSES. ALL REPAIRS OR REPLACEMENT OF FAULTY PRODUCTS WILL CONSTITUTE THE COMPREHENSIVE FULFILMENT OF HI-TECH'S OBLIGATIONS WITH RESPECT TO THE CLIENT. HI-TECH DOES NOT IN ANY WAY GUARANTEE THE SUITABILITY OR APTITUDE OF ITS PRODUCT FOR ANY PARTICULAR PURPOSE OR APPLICATION.

All of the information provided on components which have not been manufactured by HI-TECH and which is based on reports received from the original manufacturer, though considered precise and reliable, is provided without any guarantee or responsibility of any explicit or implicit kind.

All concession, sale or financial leasing of the Product by HI-TECH in no case explicitly or implicitly constitutes any authorisation, acceptance or concession for the use of any rights or patents, nor does it encourage, nurture or back their infringement.

The restrictions on the guarantee suppose no limitation on the legal rights of the consumer established in applicable national legislation, nor do they affect any rights derived from the bargain and sale agreement between the consumer and supplier.



All of the information provided in this manual has been included in the confidence that it is true, although it does not constitute any responsibility or implicit or explicit guarantee. HI-TECH reserves the right at any time without forewarning to make all necessary improvements and modifications to this manual in order to rectify any possible typographical errors, increase the information contained and enter the changes made to the characteristics and performances of the Unit.

SAFETY AND HANDLING

The equipment described in this manual has been designed and manufactured in compliance with the following European Directives, following as application guide the harmonized standards detailed and in conformity with the relevant UK Statutory Instruments (and their amendments):

Directive 2006/42/EC on machinery (UK Supply of Machinery (Safety) Regulations 2008)

UNE EN 12100:2012 (BS EN ISO 12100:2010)

Directive 2014/35/EU on electrical safety (UK Electrical Equipment (Safety) Regulations 2016)

UNE EN 60204-1:2019 (BS EN 60204-1:2018)

Directive 2011/65/EU on the restriction of the use of certain hazardous substances in electrical and electronic equipment with amendment 2015/863/EU (UK The Restriction of the Use of Certain Hazardous Substances in Electrical and Electronic Equipment Regulations 2012)

Directive 2012/19/EU on waste electrical and electronic equipment (UK The Waste Electrical and Electronic Equipment Regulations 2013)



Electrical products cannot be thrown out with the rubbish. They must be taken to a dedicated collection point for an environmentally sound disposal in accordance with local regulations. You must contact your local collective or retailer for information about recycling. Before leaving WEEE at appropriate collection facilities, batteries must be removed and disposed of separately for proper recycling. The packaging materials are recyclable. Dispose of packaging materials in an environmentally sound manner and place them at the disposal of recycling sectors.

TRANSPORT AND STORAGE

Proper precautions must be taken so that the equipment can withstand the effects of transport and storage temperatures between -25°C and +55°C or up to +70°C for short periods that do not exceed 24 hours. Also, appropriate means to prevent damage from moisture, vibrations or shocks must be foreseen.



This chapter contains important information on safety, handling and use of your Heated Hose.



Before installing and operating the hose, carefully read the technical and safety documentation in this manual. Special attention should be paid to the information for knowing and understanding the handling and conditions of use of the hose. All of the information is aimed at enhancing User Safety and avoiding possible faults due to incorrect use of the hose.

A **WARNING!** establishes information for alerting you on the situations which could cause serious injury if the instructions are not followed.

A **PRECAUTION!** establishes information which indicates how to avoid damage to the gun and how to avoid a situation which could cause minor injuries.

A **NOTE** is relevant information on the procedure being carried out.

Careful study of this manual will help you to become more acquainted with the gun and the procedures. Following the instructions and recommendations here will reduce the potential risk of accidents in installing, using or maintaining the gun, and will give you the problem-free operation for a longer time, greater output and the possibility of detecting and resolving problems quickly and simply.

Keep this Service Manual for future consultation of useful information at all times. If you lose the manual, ask for a new copy from your local **HI-TECH** distributor or make direct contact with **HI-TECH SPRAY EQUIPMENT, S. A.**

WARNING: *The heated hose's design and configuration do not allow it to be used in potentially explosive atmospheres or to exceed the pressure and temperature limits described in the technical specifications of this manual.*

Always use liquids and solvents that are compatible with the unit. In the event of doubt, consult the **HI-TECH** technical service.



When working with the hose, it is essential to dress suitably and use personal protection equipment, including the unlimited use of gloves, protective goggles, safety footwear and face masks. Use breathing equipment when working with the hose in enclosed or insufficiently ventilated atmospheres. The introduction and follow-up of safety measures must not be limited to those described in this manual. Before starting to use the hose, a rigorous analysis must be made of the risks derived from the products to be dispensed, the type of application and the working environment.

The heated hose forms part of the projection equipment, which is why all safety measures must be taken that are provided for the start-up use of the equipment, in addition to all specific measures for the use of the hose.



Carefully read the safety data sheet provided by your supplier to prevent any possible injury caused by incorrect handling of the raw materials and solvents used in the process.

Deal with the waste caused according to current regulations.



To prevent serious damage caused by the impact of fluids under pressure, never open a connection or do maintenance work on components subject to pressure until you are sure that all pressure has been eliminated.



Use suitable protection when operating, maintaining or simply being in the area where the equipment is working. This includes, but is not limited to, the use of protective goggles, gloves, shoes and safety clothes and breathing equipment.

The equipment includes components which reach high temperatures and may cause burns. The hot parts of the unit must not be handled or touched until they have completely cooled.



To prevent serious injury caused by crushing or amputations, do not work with the equipment if the moving part safety protections are not duly installed. Make sure that all safety protections are correctly fitted after carrying out repair or maintenance work on the equipment



CHARACTERISTICS

- The hoses meet the requirements of ISO 3949:2018, type R7 for low pressure and type R8 for high pressure.
- The hoses consist of a seamless thermoplastic polyurethane cover, polyamide inner tube and a suitable textile fiber reinforcement. The R8 version also incorporates an additional aramid layer.
- Hoses manufactured with braided copper sheath for a uniform heating of each product.
- Vulcanized hoses and individually protected with an insulating cover to minimize heat losses.
- Fittings of different sizes ("A" ISO 1/2"-20 JIC, "R" RESIN 9/16"-18 JIC) to prevent an incorrect hose connection.
- The female hose fitting indicates the inlet of the product and the male fitting for the outlet.
- The fittings shall be marked with the date of manufacture in 4-digit format for traceability of the manufacturing batch.
- Hose ends differentiated by color (red "A" ISO and blue "R" RESIN) to quickly identify the corresponding product.
- Main hose 15m long and 3m whip hose, both heated.
- Up to 93m of complete heated hose assembly (six 15m sections and one 3m whip hose), depending on the machine configuration.
- "Fast-lock" system for electrical connections.
- Dedicated antistatic air line with 1/4" NPT fittings.
- Type E thermocouple extension cable for product temperature control, depending on the hose model.
- Female/male electrical connectors with safety clip and watertight seal for signal transmission from the gun's microswitch and/or timer and the machine, when required.
- Wear-resistant scuff jacket to protect the hoses and their components, depending on the model.
- Detachable rubber covers with zip ties to cover each connection between hose sections, depending on the model.

SPECS

Heated Hoses Maximum Operating Temperature: _____ **85° C**
Maximum Operating Pressure Air Hose: _____ **9 bar (0,9 MPa)**



STANDARD 2 COMPONENT HOSE

Table 1. - 15 m length x 3/8" ID							
Part number	Heated	Scuff Jacket	TSU cable	WP (bar)	Individual Lines		Air line
					A	R	
MA-00014	✓			155	MA-00014-A	MA-00014-R	MA-00104
MA-00014-E	✓		MA-00006E	155	MA-00014-A	MA-00014-R	MA-00104
MA-00014-S	✓	MA-00123-50		155	MA-00014-A	MA-00014-R	MA-00104
MA-00014-E-S	✓	MA-00123-50	MA-00006E	155	MA-00014-A	MA-00014-R	MA-00104
MA-00039	✓			275	MA-00039-A	MA-00039-R	MA-00104
MA-00039-E	✓		MA-00006E	275	MA-00039-A	MA-00039-R	MA-00104
MA-00039-S	✓	MA-00123-50		275	MA-00039-A	MA-00039-R	MA-00104
MA-00039-E-S	✓	MA-00123-50	MA-00006E	275	MA-00039-A	MA-00039-R	MA-00104
MA-00065-E	(1)	MA-00123-50	MA-00006E	275	MA-00065-A	MA-00065-R	MA-00104

(1) Individual heated A and R lines, prepared for machines with 2 transformers.

WHIP HOSE

Table 2. - 3 m length x 1/4" ID						
Part number	Heated	Scuff Jacket	WP (bar)	Individual Lines		Air line
				A	R	
MA-00038	✓	MA-00129 (1)	195	MA-00038-A	MA-00038-R	MA-00105
MA-00040	✓	MA-00129 (1)	345	MA-00040-A	MA-00040-R	MA-00105
MA-00064	(2)	MA-00129 (1)	345	MA-00064-A	MA-00064-R	MA-00105

(1) Order 3,9 m for the complete line.

(2) Individual heated A and R lines, prepared for machines with 2 transformers.



STANDARD 2 COMPONENT HOSE @230V

Table 3. - 20 m length x 3/8" ID							
Part number	Heated	Scuff Jacket	TSU cable	WP (bar)	Individual Lines		Air line
					A	R	
MA-00203-E	✓	MA-00123 (1)	MA-00006-02E	275	MA-00203-A	MA-00203-R	MA-00212

(1) Order 20 m for the complete line.

END SECTION WHIP HOSE

Table 4. - 0,65 m length x 1/4" ID							
Part number	Heated	Scuff Jacket	TSU cable	WP (bar)	Individual Lines		Air line
					A	R	
MA-00022		MA-00129 (1)		345			
MA-00023		MA-00129 (1)		345			

(1) Order 0,6 m for the complete line.

TEMPERATURE SENSING UNIT

Table 5. - Fluid temperature sensor					
Part number	Controlling	WP (bar)	Individual components		
			A	R	Protection Cover
EL-00051-00E	A line	345	EL-00051-02E	EL-00051-03	MA-00102
EL-00052-00E	A & R line	345	EL-00051-02E	EL-00052-02E	MA-00102

ELECTRICAL HOSE CONNECTION

Table 6. - Electrical hose connection				
Part number	Individual components			
	A	R	Hex socket stud	Hex socket stud nylon
KT-00029-PKG	KT-00029-A	KT-00029-A	TN-00241	TN-00242



CUSTOM 2 COMPONENT HOSE

Table 7. - Custom 2 component hose 3/8" ID							
Part number	Length (m)	Heated	Scuff Jacket	TSU cable	WP (bar)	Notes	Air line
MA-00015	3	✓	MA-00129 (1)		155		MA-00105
MA-00039-01-S	15	✓	MA-00123-50	(2)	275		MA-00104
MA-00039-ER-S	15	✓	MA-00123-50	MA-00006E	275	(3)	MA-00104
MA-00094	3	✓	MA-00129 (1)		275		MA-00105
MA-00095-E-S	30	✓	MA-00123 (4)		275		✓
MA-00135-E-S	15	✓	MA-00123-50	MA-00006E	155	(5)	MA-00104
MA-00211-E-S	15	✓	MA-00123-50	MA-00006E	275	(5)	MA-00104

(1) Order 3,9 m for the complete line.

(2) RTD sensor.

(3) Temperature control for R line.

(4) Order 31 m for the complete line.

(5) With extra breathing air hose.

AIRLESS HOSE

Table 8. - Airless Hose							
Part number	Length (m)	Heated	Scuff Jacket	TSU cable	WP (bar)	ID in.	Air line
ASP-00	15				220	3/8	
ASP-01	1				228	1/4	



GENERAL DESCRIPTION

In the basic model, each set of heated hoses consists of a first modular section 15m long connected to a final section 3m long. These sections may be high or low pressure and may have two different sizes (1/4" or 3/8").

As many 15m modular sections as the machine's transformer can handle may be added, paying attention to the internal connection of the transformer, depending on the total hose length installed (refer to the machine's Service Manual).

Each pair of heated hoses, differentiated by colour and size of the threaded connections, is equipped with an air hose and a wear-resistant sheath (depending on the model) that protects the entire assembly. Two "Fast-lock" connectors are also included for connecting the voltage cables between sections.

Depending on the requirements in each case, additional components can be added to each section, such as independent heating connections for each product hose, probe(s) for temperature control, wiring for microswitches, hoses for recirculation, etc.

Each hose assembly is individually tested at our installations. During manufacturing, the continuity and resistance of the copper braiding is checked. After the threaded terminals have been pressed, they are checked for pressure resistance and watertightness, and any moisture inside the lines is removed. Lastly, the ends are sealed with threaded plugs and are ready for installation.



METHOD OF THREADED UNION OF THE HOSES

Follow the torques for threaded joints listed in **Table 9** according to thread sizes of hose fittings to ensure their proper assembly.

There is also an alternative procedure to obtain an equivalent torque without using special tools: joint both ends of the hoses to be connected, tighten a swivel nut by hand (without using spanner) until there is resistance on the nut. Fit two spanners (1) on the fixed ends of the hoses and turn the swivel nut with a third spanner (2) as many flats from wrench resistance (FFWR) as indicated in **Table 9**.

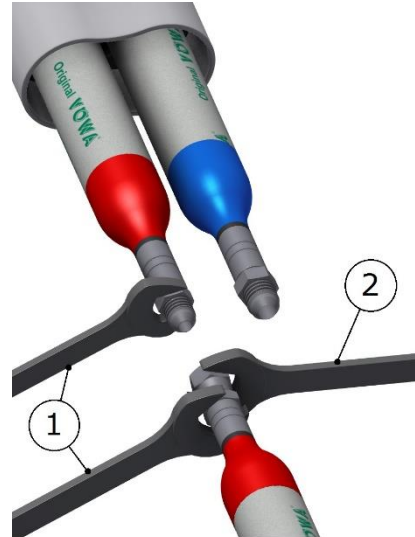
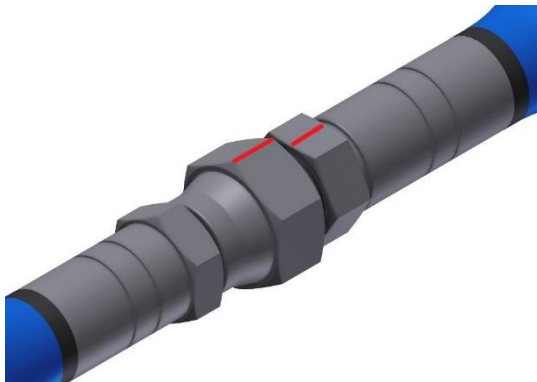

Table 9. - Tightening Threaded Joints

THREAD SIZE	TORQUE Nm	FFWR
1/2"-20	23	2 (or 120°)
9/16"-18	30	1-1/2 (or 90°)

NOTE: 1 FFWR corresponds to one complete shear of a flat marked with red between swivel and fitting or else 60°.





INSTALLATION

Connecting the last hose section to the gun

CAUTION: When servicing or installing hoses, wear appropriate protection as indicated in the recommendations and specifications provided by the product suppliers. Also, make sure that the machine is stopped, depressurized and disconnected from electrical power.

1. Completely close the manual valves on the gun intake block by turning them clockwise. The manual valves control the flow of each product into the chamber and are located in the "Coupling Block".
2. Connect the air supply hose to the connector on the rear of the gun.
3. Connect the Isocyanate hose (red end) to the Isocyanate intake connector (letter A) on the "Coupling Block".
4. Connect the Polyol hose (blue end) to the Polyol intake connector (letter R) located on the Coupling Block.

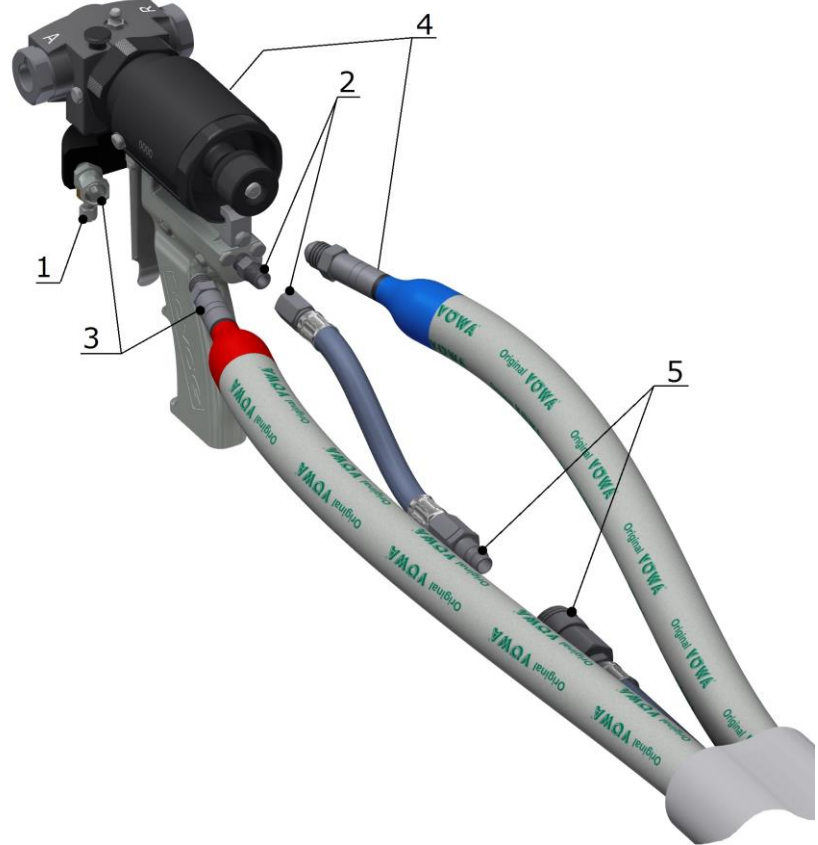

NOTE: The product hoses have been differentiated with the colours red and blue to allow quick identification. Red corresponds to the Isocyanate hose and Blue to the Polyol hose. To avoid connection errors, the coupling connectors of the Isocyanate and Polyol hoses are different sizes, which makes it impossible to mix up the connections.

5. Connect the air valve.

WARNING! To connect the hoses to the gun, use the procedure indicated in page 11



Connecting Hose Sections

Line up the ends of the product hoses by matching the colours.
Connect the product hoses "A" ISO and "R" POL.

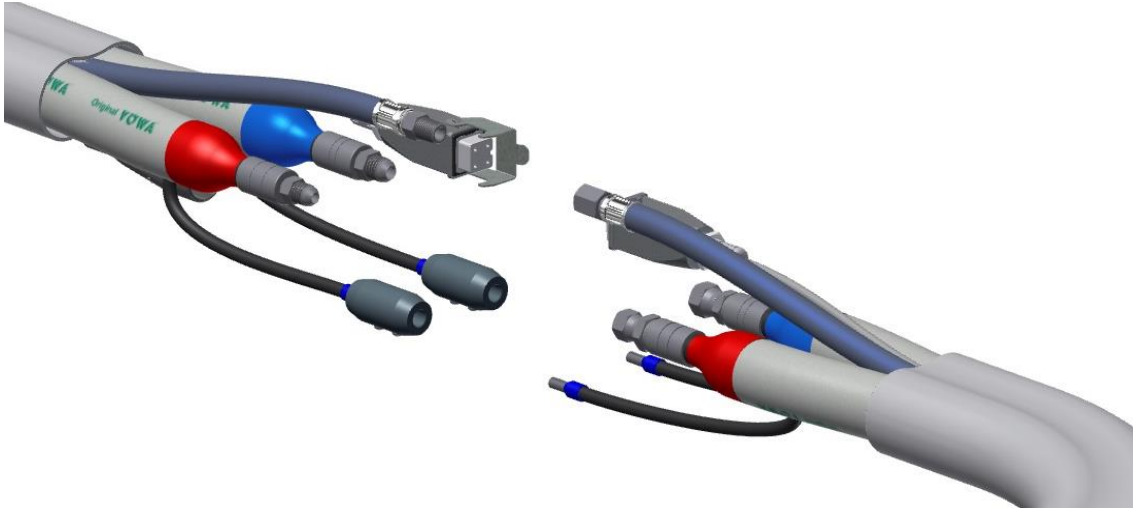

WARNING! To join the hoses together or to connect them to the heaters or the gun, use the procedure indicated in page 11.

Connect the Air Hose Supply (if applicable).

Connect the gun mic cable (if applicable).

Connect the resistance terminals of the hoses. To do this, you must insert the terminal of the resistance of the next hose into the pin of the "Fast-lock" of the previous hose section. Fix it with the metal stud and secure it with the nylon stud. Check that both terminals are secure. Take care not to cross the terminals of the "A" ISO hose with those of the "R" POL hose.

Attach the probe connectors (if applicable).

When connecting the last section, a probe is usually installed to monitor the temperature, at least in the "A" ISO line.

To do this, insert the probe wire in the male connector of the product hose coming from the machine, being careful not to bend or damage the wire. Secure the threaded connections using the same procedure for connecting the hoses and connect the probe connector to the hose connector.

Secure the connectors with a nylon zip tie.

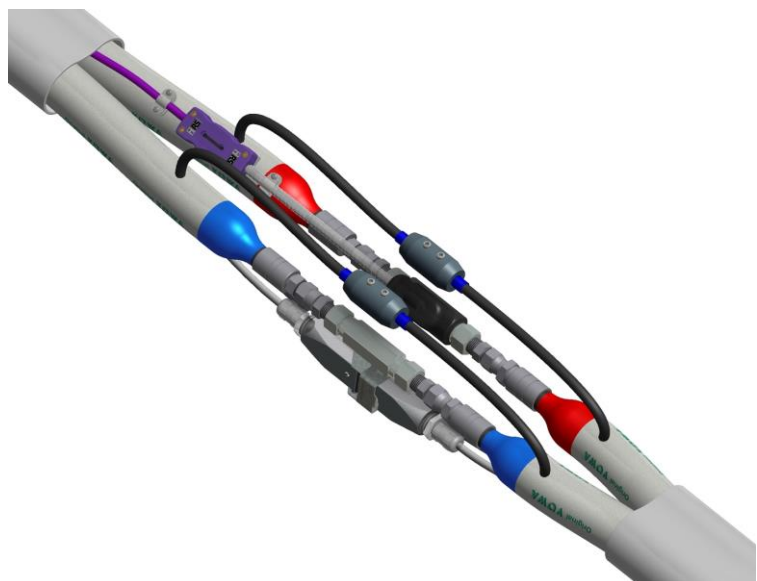



Arrange all of the components and wiring to take up as little space as possible. Wrap the joint with insulating tape and cover the entire package with the rubber covers and secure with zip ties.

Lastly, pull the ends of each hose sleeve and cover the entire joint.

If a probe is installed, it will normally be in the "A" ISO line and in the "R" POL hose connection, an extension, supplied with the probe kit, should be installed, following the same procedure for connecting the threaded parts. If another probe is installed on the "R" POL side, follow the steps for the installation of the probe on the "A" ISO side.

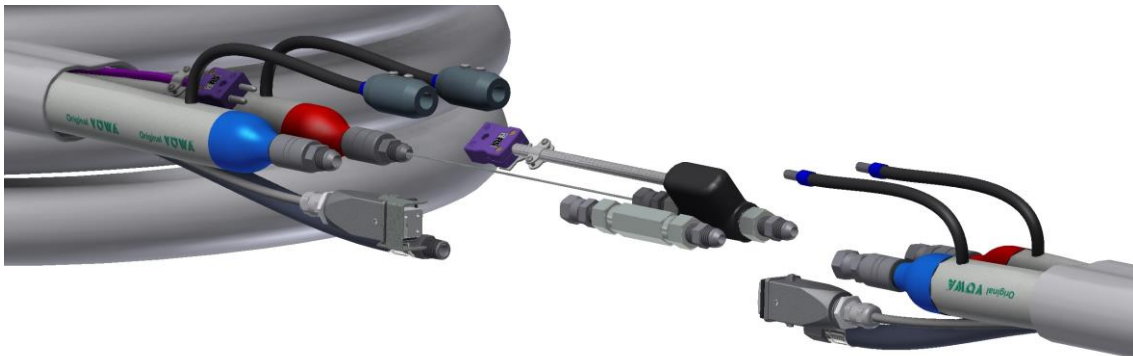



Connecting the first hose section to the machine

- 1) Connect the product hoses "A" ISO and "R" POL to the outlet connectors of the corresponding heaters.

WARNING! To connect the hoses to the outlet of the heaters, use two wrenches to hold the fixed parts to be connected (1) and use a third wrench to tighten or loosen (as appropriate) the connecting nut (2). The tightening torque for these joints should be the one indicated in the page 11.

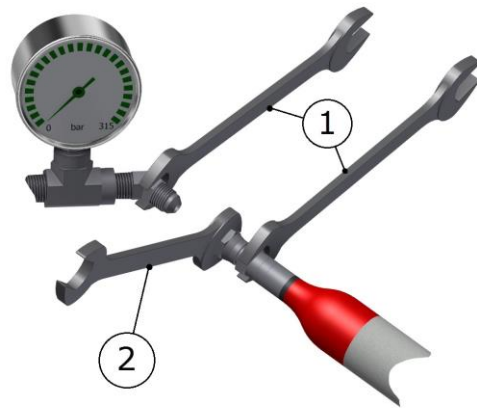

- 2) Connect the terminals of the hose heating to the "Fast-lock" of the transformer outlet. Secure them with the metal studs and secure them with the nylon studs. Make sure that both terminals are securely fastened. For machines with two transformers, this operation must be repeated for the second unit.

NOTE: For machines with a single transformer, the current is the same in both hose lines, for machines with two transformers, the current is independent in both hose lines, and can be regulated individually.

- 3) Connect the air intake of the hose to the air system. The connecting stud is supplied with the machine.
- 4) Plug in the probe connector (if applicable). With machines with two transformers, one probe can be installed for the "A" ISO hose and another for the "R" POL hose. The connectors on the hoses will be differentiated to avoid mixing them up (female connector for ISO probe "A" and male connector for POL probe "R"). Cover the connectors with the covers provided.

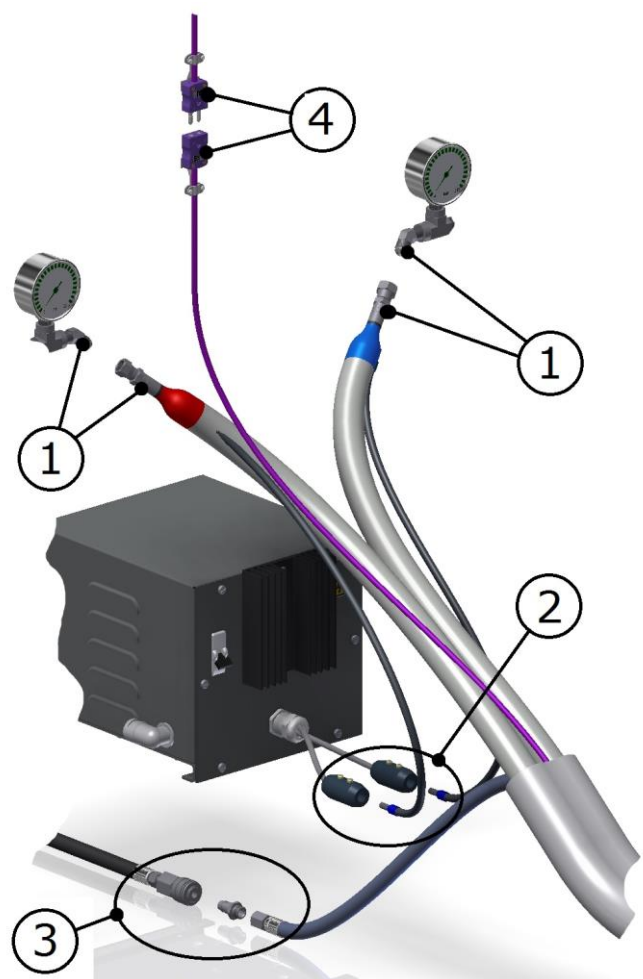



START UP

CAUTION: *Before starting the unit, make sure that all of the sections are properly attached to the gun and the machine. Take a moment to check for leaks.*

Checking for leaks

After all of the sections have been connected and the hose is connected to the machine and the gun, verify the operating pressure of the hose before starting to apply pressure with the machine.

Also make sure you have connected the gun's "Coupling Block" and closed the product taps.

After the check have been carried out, turn on the machine so that it starts pumping the product to the hoses. Refer to the machine-specific Service Manual for the process to prime the system.

Once the hoses are pressurized, check for leaks. If not, you should release the pressure from the hoses, retighten the fittings and check again for leaks.

NOTE: *After the hose installation has been tested, leave the connections with the cables and hoses as far apart as possible, without forcing them to bend too far, which could damage them. Secure all elements with insulating tape, wrap with the rubber covers and fasten with plastic zip ties to protect the joint. Lastly, cover with the wear-resistant sleeve by pulling the ends and make them overlap as much as possible.*



SHUTDOWN PROCEDURE

Refer to the corresponding section described in the machine's Service Manual.

In this operation, it is recommended that the hoses are pressurized to 30 bar with product inside and hermetically sealed.

CLEANING PROCEDURE

Refer to the corresponding section described in the machine's Service Manual.

To empty the hoses, clean and refill them with product.

TEMPORARY SHUTDOWN

Refer to the corresponding section described in the machine's Service Manual.

When you plan to stop the unit for more than FOUR weeks, you will need to replace the products contained in the installation with DOTP plasticizer oil.

NOTE: *Never use liquids that are not recommended or approved by Hi-Tech Spray Equipment, S.A., as well as recommended or approved liquids that are contaminated with water or ISO/POL. If you are unsure of the quality of the liquid you are going to use, we recommend that you check the machine 2-3 times every 2 weeks after filling it by recirculating it through the heated hoses with new plasticizer, unless you ensure that the liquid coming out is completely pure and clean.*



MAINTENANCE

To achieve maximum performance from the unit, certain daily or regular maintenance operations are needed.



To prevent possible bodily harm caused by incorrect handling of the raw materials and solvents used in the process, carefully read the safety information provided by your supplier.

Deal with the waste created according to current regulations.



Disconnect the unit from the power supply before carrying out any operation inside the electrical console.

The electrical maintenance of the machine must only be performed by a qualified electrician.



To avoid damage caused by the impact of pressurized fluids, do not open any connection or perform maintenance work on components subject to pressure until the pressures have been completely eliminated.



Use suitable protection when operating, maintaining or remaining in the operating area of the unit. This includes, but is not limited to, the use of face masks, protective goggles, gloves, shoes and safety clothing.

The unit includes components that reach temperature that are liable to cause burns. The hot parts of the unit must not be handled until they have cooled.



To prevent serious harm by crushing or loss of limbs, do not work with the unit without the safety duly installed on all moving parts. Make sure that all of the safety protections are correctly fitted after all repair or maintenance work.

Visually check the condition of the hose

Do not roll up the hoses with a radius of under one meter / 4 feet.

To protect the TCS sensor, you must pay special attention not to kink or excessively bend the hoses.

Do not exceed the pressure and temperature limits specified on the hose, it could cause serious bodily harm.

Always check the good condition of the gun and its components, as an anomaly could cause the reacted product to fall back and contaminate the hoses by making a plug.



TROUBLESHOOTING

PRECAUTION! Use suitable protection and follow the recommendations in the safety information provided by product suppliers when installing or working with the unit.

All repairs performed by unqualified personnel or the use of spares other than originals may cause damage to the unit and put the operator at risk.

This accessory has been designed and built to withstand severe working conditions with a high degree of reliability, provided it is used suitably. This chapter contains information on possible faults that may prevent the continuation of work with the unit. The information provided must serve as guideline to detect and resolve the large majority of the problems before calling for the assistance of the authorized distributor or **HI-TECH** technical service. In any case, feel free to contact the technical assistance service of **HI-TECH SPRAY EQUIPMENT**, where a qualified technician will advise you on whatever you may need.

WARNING! Before resolving any kind of defect, make sure all of the pushbuttons are off, that the general switch is in shutdown position and that the unit is disconnected from the power supply source. Never handle the inside of the control panel with the unit connected to the power supply. The hoses can reach high temperatures; wait until they have cooled before handling.

If a fault occurs in the heating system of the hoses, an alarm will be activated and the number 9 will be shown on the control panel.

Follow the recommended procedure in the order indicated, to try to solve the problem and avoid costly repairs. Make sure all the automatic switches and control elements are in the correct working position before determining the existence of a fault.

PROBLEMS

- The hose is hot, but fails to reach the selected temperature.
- The hose is not hot; the pushbutton led is lit.
- Only the sections of the hose closest to the unit are heated.
- The hose display shows the symbol (---).
- The automatic switch is triggered.

SOLUTIONS

- 1-2-7
- 2-3-4-5
- 5
- 6
- 3

SOLUTIONS

1. Hose Length

The units have been designed to work with a maximum hose length of 93 meters. A longer length will render the heating capacity less effective. Under extreme ambient conditions, the hose heating system may be affected and fail to reach the required temperature.



2. Hose Transformer

The transformer offers the option of connecting the hose to an output voltage of 40 V (for a 3 kW transformer) and 45 V (for a 4 kW transformer), valid for connecting hose sections with a total length of up to 48 meters, or to 75 V output voltage (for 3 kW transformer) and 90 V (for 4 kW transformer), valid for connecting lengths greater than 48 meters up to a maximum of 93 meters; connect to one or the other position depending on the total hose length installed in the machine. If the connection is performed incorrectly, the hoses will not reach the required temperature.

3. Automatic Switch

This protects the secondary circuit of the transformer. The switch is located on the front of the transformer; make sure it is activated, otherwise activate it. Replace it with one of equal amperage if the switch fails to work correctly.

PRECAUTION! *The replacement of the automatic switch with another of different characteristics may cause damage to the equipment and put the operator at risk.*

4. Triac

This determines that the triac is faulty when all of the previous checks have been correct. Replace the triac if it fails to work correctly.

5. Hose Heating Components

With the general switch turned off, make sure the hose connections and the electrical connections between the hoses and the unit are correct and tight. If the connections are correct and the hoses do not heat up, check section by section to locate the connection that is at fault.

Proceed as follows:

- a) Disconnect the unit from the power supply by deactivating the general switch and start to check the hose section closest to the gun. Remove the "Fast Lock" connector, and make a "bridge" on the connection immediately before.
- b) Restore the power supply, press the POWER CONTROL key and the ISO and RESIN keys under the HOSES display. If the heating works, the problem will be in the last section of hose. Replace it. If not, do the following.
- c) Disconnect the unit from the power supply, remove the "Fast Lock" connector from the last section of hose and make a "bridge" on the connection immediately before.
- d) Restore the power supply, press the POWER CONTROL key and the ISO and RESIN keys under the HOSES display. If the heating works, the problem will be in the last but one section of hose. Replace it. If not, repeats steps c) and d) until you find the point of the fault.

6. TCS Temperature Control

The control panel automatically detects any fault in the operation of the temperature sensor. To determine if the mistake is caused by the proper probe or by a defective electrical connection, realize the following cross-check: dismantling the electrical connector of the probe TCS of the last stretch of hose and without dismantling any other connection connect it straight to the electrical capture of the exit of the machine, if the control is restored check the electrical connections of the probe existing TCS in the intermediate stretches of the hoses, in the opposite case replace the probe TCS.

7. Hose Heating Temperature Adjustment

The hose heating system maintains the temperature of the products exiting the heaters, which is why the value set for the temperature of the hoses must be the same or 10°C less than the selected on the heater display.



CONTENT

WARRANTY	2
Safety and Handling	3
Characteristics	6
specs	6
Standard 2 Component Hose	7
Whip Hose	7
Standard 2 Component Hose @230V	8
End Section Whip Hose	8
Temperature Sensing Unit	8
Electrical Hose Connection	8
Custom 2 component hose	9
Airless Hose	9
General Description	10
METHOD OF THREADED Union OF THE HOSES	11
Instalation	12
Connecting the last hose section to the gun	12
Connecting Hose Sections	13
Connecting the first hose section to the machine	15
Start up	16
Checking for leaks	16
Shutdown Procedure	17
Cleaning Procedure	17
Temporary Shutdown	17
Maintenance	18
Troubleshooting	19
Content	21
List of Tables	22



LIST OF TABLES

Table 1. - 15 m length x 3/8" ID _____	7
Table 2. - 3 m length x 1/4" ID _____	7
Table 3. - 20 m length x 3/8" ID _____	8
Table 4. - 0,65 m length x 1/4" ID _____	8
Table 5. - Fluid temperature sensor _____	8
Table 6. - Electrical hose connection _____	8
Table 7. - Custom 2 component hose 3/8" ID _____	9
Table 8. - Airless Hose _____	9
Table 9. - Tightening Threaded Joints _____	11