

Service Manual

Spray Gun

novaG-A Series

1.6 Issue 18/08/2022
Ref. NR-00016-ENG



Before installing and operating the novaG-A gun, carefully read the technical and safety documentation in this manual. Special attention should be paid to the information in order to know and understand the handling and conditions of use of the Unit. All of the information is aimed at enhancing User Safety and avoiding possible faults due to incorrect use of the Unit.



WARRANTY

HI-TECH SPRAY EQUIPMENT, S. A. (hereinafter "HI-TECH") grants this Limited Guarantee to the original buyer (hereinafter the "Client") for the unit and the original accessories given with the unit (hereinafter the "Product") against any fault in the design, materials or manufacture of the Product at the time of the first purchase by the user and for a duration of two (2) years thereafter.

If during the guarantee period and under normal conditions of use, the Product should fail to work correctly due to defects of design, material or manufacture, the authorised distributor of the country where the HI-TECH Product or technical assistance service has been purchased shall repair or replace the Product in accordance with what is established in the following:

CONDITIONS

- a) The validity of this guarantee will be subject to the presentation of the original invoice issued by the HI-TECH authorised distributor for the sale of the Product along with the Product handed over for repair or replacement, which must show the date of purchase and the serial number. HI-TECH reserves the right to refuse to give the guarantee service when the indicated data fail to appear on the invoice or have been modified after the purchase of the Product.
- b) The repaired or replaced Product will continue to maintain the original guarantee for the time remaining until the end of the guarantee or for three (3) months from the repair date, if the remaining period of the original guarantee were shorter.
- c) This guarantee will not be applied to the faults in the Product caused by its faulty installation, the natural wear and tear of the components, any use other than that considered normal for this Product or which should fail to strictly comply with the instructions of use provided by HI-TECH; due to accident, carelessness, adjustments, alterations or modifications of the Product not authorised by HI-TECH or due to the use of accessories, heating devices, pumping equipment and/or dispensers that have not been approved or manufactured by HI-TECH.
- d) The guarantee applicable to the components and accessories forming part of the Product and which have not been made by HI-TECH will be limited to the guarantee offered by the original manufacturer thereof.

HI-TECH WILL NOT RECOGNISE ANY EXPRESS ORAL OR WRITTEN GUARANTEES OTHER THAN THIS PRINTED LIMITED GUARANTEE. ALL IMPLICIT GUARANTEES, INCLUDING, WITHOUT LIMIT, ADAPTATION FOR A SPECIFIC USE, ARE SUBJECT TO THE DURATION OF THIS WRITTEN GUARANTEE. HI-TECH DOES NOT ASSUME ANY KIND OF COMMITMENT OR RESPONSIBILITY FOR ALL POSSIBLE DAMAGE OR EXPENSE CAUSED BY FAULTS IN THE OUTPUT OF THE PRODUCT, ITS WORKING OR THE DISPENSING OF MATERIAL THROUGH THE PRODUCT, INCLUDING, WITHOUT LIMITATION, ALL EXPENSES CAUSED BY DAMAGE TO PEOPLE OR PROPERTY. EQUALLY, HI-TECH WILL IN NO CASE ACCEPT LIABILITY FOR THE LOSS OF SPECULATIVE PROFITS OR COMMERCIAL LOSSES. ALL REPAIRS OR REPLACEMENT OF FAULTY PRODUCTS WILL CONSTITUTE THE COMPREHENSIVE FULFILMENT OF HI-TECH'S OBLIGATIONS WITH RESPECT TO THE CLIENT. HI-TECH DOES NOT IN ANY WAY GUARANTEE THE SUITABILITY OR APTITUDE OF ITS PRODUCT FOR ANY PARTICULAR PURPOSE OR APPLICATION.

All information provided on components which have not been manufactured by HI-TECH and which is based on reports received from the original manufacturer, though considered precise and reliable, is provided without any guarantee or responsibility of any explicit or implicit kind.

All concession, sale or financial leasing of the Product by HI-TECH in no case explicitly or implicitly constitutes any authorisation, acceptance or concession for the use of any rights or patents, nor does it encourage, nurture or back their infringement.

The restrictions on the guarantee suppose no limitation on the legal rights of the consumer established in applicable national legislation, nor do they affect any rights derived from the bargain and sale agreement between the consumer and supplier.

All information provided in this manual has been included in the confidence that it is true, although it does not constitute any responsibility or implicit or explicit guarantee. HI-TECH reserves the right at any time and without prior warning to make all improvements and modifications necessary to this manual, in order to rectify any possible typographical errors, increase the information contained or insert the changes caused to the characteristics and performance of the unit.



SAFETY AND HANDLING

The equipment described in this manual has been designed and manufactured in compliance with the following European Directives, following as application guide the harmonized standards detailed and in conformity with the relevant UK Statutory Instruments (and their amendments):

Directive 2006/42/EC on machinery (UK Supply of Machinery (Safety) Regulations 2008)

UNE EN 12100:2012 (BS EN ISO 12100:2010)

UNE EN 1953:2013 (BS EN 1953:2013)

Directive 2014/68/EU on pressure equipment (UK Pressure Equipment (Safety) Regulations 2016)

UNE EN 809:1999 +A1 (BS EN 809:1998 +A1:2009)

Directive 2011/65/EU on the restriction of the use of certain hazardous substances in electrical and electronic equipment with amendment 2015/863/EU (UK The Restriction of the Use of Certain Hazardous Substances in Electrical and Electronic Equipment Regulations 2012)

Directive 2012/19/EU on waste electrical and electronic equipment (UK The Waste Electrical and Electronic Equipment Regulations 2013)



Electrical products cannot be thrown out with the rubbish. They must be taken to a dedicated collection point for an environmentally sound disposal in accordance with local regulations. You must contact your local collective or retailer for information about recycling. Before leaving WEEE at appropriate collection facilities, batteries must be removed and disposed of separately for proper recycling. The packaging materials are recyclable. Dispose of packaging materials in an environmentally sound manner and place them at the disposal of recycling

sectors.

TRANSPORT AND STORAGE

Proper precautions must be taken so that the equipment can withstand the effects of transport and storage temperatures between -25°C and +55°C or up to +70°C for short periods that do not exceed 24 hours. Also, appropriate means to prevent damage from moisture, vibrations or shocks must be foreseen.



This chapter contains important information on safety, handling and use of your **NOVAG** New **NOVAG-A** gun.



Before installing and operating the gun, carefully read the technical and safety documentation in this manual. Special attention should be paid to the information for knowing and understanding the handling and conditions of use of the gun. All of the information is aimed at enhancing User Safety and avoiding possible faults due to incorrect use of the gun.

A **WARNING!** establishes information for alerting you on the situations which could cause serious injury if the instructions are not followed.

A **PRECAUTION!** establishes information which indicates how to avoid damage to the gun and how to avoid a situation which could cause minor injuries.

A **NOTE** is relevant information on the procedure being carried out.

Careful study of this manual will help you to become more acquainted with the gun and the procedures. Following the instructions and recommendations here will reduce the potential risk of accidents in installing, using or maintaining the gun, and will give you the problem-free operation for a longer time, greater output and the possibility of detecting and resolving problems quickly and simply.

Keep this Service Manual for future consultation of useful information at all times. If you lose the manual, ask for a new copy from your local **HI-TECH** distributor or make direct contact with **HI-TECH SPRAY EQUIPMENT, S. A.**

WARNING: *The gun's design and configuration do not allow it to be used in potentially explosive atmospheres or to exceed the pressure and temperature limits described in the technical specifications of this manual.*

Always use liquids and solvents that are compatible with the unit. In the event of doubt, consult the **HI-TECH** technical service.



Manual Service

When working with the gun, it is essential to dress suitably and use personal protection equipment, including the unlimited use of gloves, protective goggles, safety footwear and face masks. Use breathing equipment when working with the gun in enclosed or insufficiently ventilated atmospheres. The introduction and follow-up of safety measures must not be limited to those described in this manual. Before starting to use the gun, a rigorous analysis must be made of the risks derived from the products to be dispensed, the type of application and the working environment.

The gun forms part of the projection equipment, which is why all safety measures must be taken that are provided for the start-up use of the equipment, in addition to all specific measures for the use of the gun.



Carefully read the safety data sheet provided by your supplier to prevent any possible injury caused by incorrect handling of the raw materials and solvents used in the process.

Deal with the waste caused according to current regulations.



To prevent serious damage caused by the impact of fluids under pressure, never open a connection or do maintenance work on components subject to pressure until you are sure that all pressure has been eliminated.



Use suitable protection when operating, maintaining or simply being in the area where the equipment is working. This includes, but is not limited to, the use of protective goggles, gloves, shoes and safety clothes and breathing equipment.

The equipment includes components which reach high temperatures and may cause burns. The hot parts of the unit must not be handled or touched until they have completely cooled.



To prevent serious injury caused by crushing or amputations, do not work with the equipment if the moving part safety protections are not duly installed. Make sure that all safety protections are correctly fitted after carrying out repair or maintenance work on the equipment



CHARACTERISTICS

- * High-pressure internal mixture
- * Automatical cleaning by pressurised air
- * No solvents required
- * Mechanical spraying
- * Exterior greasing of the mix chamber

Approximate weight: 1 Kg

Dimensions: H 19 cm / W 9 cm / L 19 cm

SPECIFICATIONS

Maximum working pressure: _____ 240 bar (24 MPa)

Required air pressure: _____ 6-8 bar (0.6-0.8 MPa)

Maximum production ratio 1:1: _____ 18 Kg/min

Minimum production ratio 1:1: _____ 1.5 Kg/min

Opening force @ 6 bar: _____ 99 Kg

Closing force @ 6 bar: _____ 119 Kg

Approximate air consumption @ 6 bar (50 series/min): _____ 307 litres/minute

A-weighted sound pressure level: _____ 76,8 dB (A)

A-weighted sound power level: _____ 87,4 dB (A)

Values obtained according to UNE-EN ISO 3746:1995 standard.



GENERAL DESCRIPTION

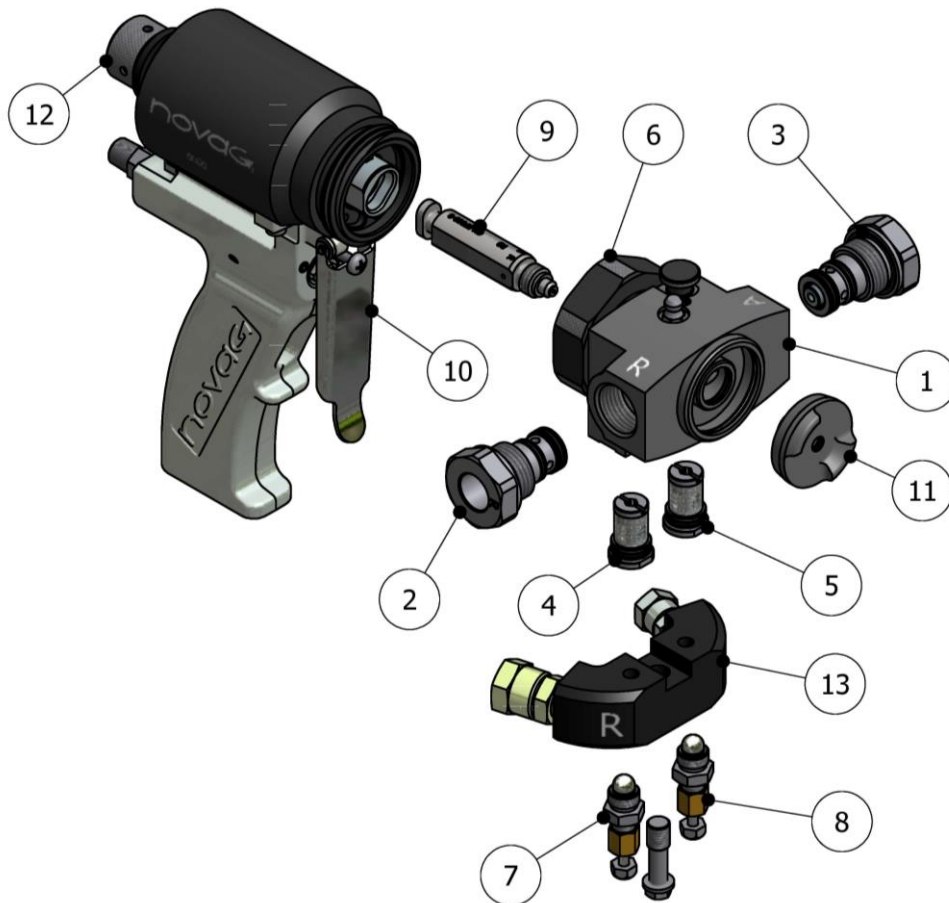

The main components and their description are given for better knowledge of the elements of the **novaG-A** gun. For a more precise identification, see the Components Manual ref. NR-00015-ENG.

1. Head Unit.
2. Polyol Side Cartridge Unit
3. Isocyanate Side Cartridge Unit
4. Polyol Non-Return Cartridge Unit.
5. Isocyanate Non-Return Cartridge Unit.
6. Head Fixing Nut.
7. Polyol Manual Valve
8. Isocyanate Manual Valve
9. Mix chamber
10. Trigger
11. Diffuser.
12. Blocking Device
13. Coupling block.



METHOD OF THREADED UNION OF THE HOSES

Follow the torques for threaded joints listed in **Table 1** according to thread sizes of hose fittings to ensure their proper assembly.

There is also an alternative procedure to obtain an equivalent torque without using special tools: joint both ends of the hoses to be connected, tighten a swivel nut by hand (without using spanner) until there is resistance on the nut. Fit two spanners (1) on the fixed ends of the hoses and turn the swivel nut with a third spanner (2) as many flats from wrench resistance (FFWR) as indicated in **Table 1**.

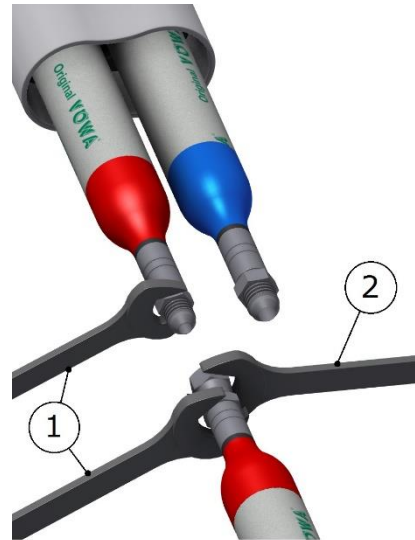

THREAD SIZE	TORQUE Nm	FFWR
1/2"-20	23	2 (or 120°)
9/16"-18	30	1-1/2 (or 90°)

NOTE: 1 FFWR corresponds to one complete shear of a flat marked with red between swivel and fitting or else 60°.





INSTALLATION AND START-UP

PRECAUTION: When working with the gun or doing maintenance on it, all suitable protection must be used in accordance with the recommendations and specifications given by the product suppliers.

NOVAG provides a series of tools and accessories which are necessary for assembling the gun. The unit is made up of the following elements:

49gr. Tube of grease	BI-00009	1x
5/16" Tube spanner	HT-00054	1x
Bits for cleaning	HT-00060	1x
Air hose supply	MA-00027	1x
Quick connect	RA-00109	1x
Adapter	RA-00110	1x
Service Manual	NR-00015	1x
Parts Identification Manual	NR-00016	1x

1. Completely close the manual valves by turning them clockwise. The manual valves control the input flow of each product to the chamber and are located on the Coupling Block.
2. Connect the air supply pipe to the connector at the rear of the gun.
3. Connect the Isocyanate hose (red terminal) to the Isocyanate input connector (letter A) on the Coupling Block.
4. Connect the Polyol hose (blue terminal) to the Polyol input connector (letter R) on the Coupling Block.

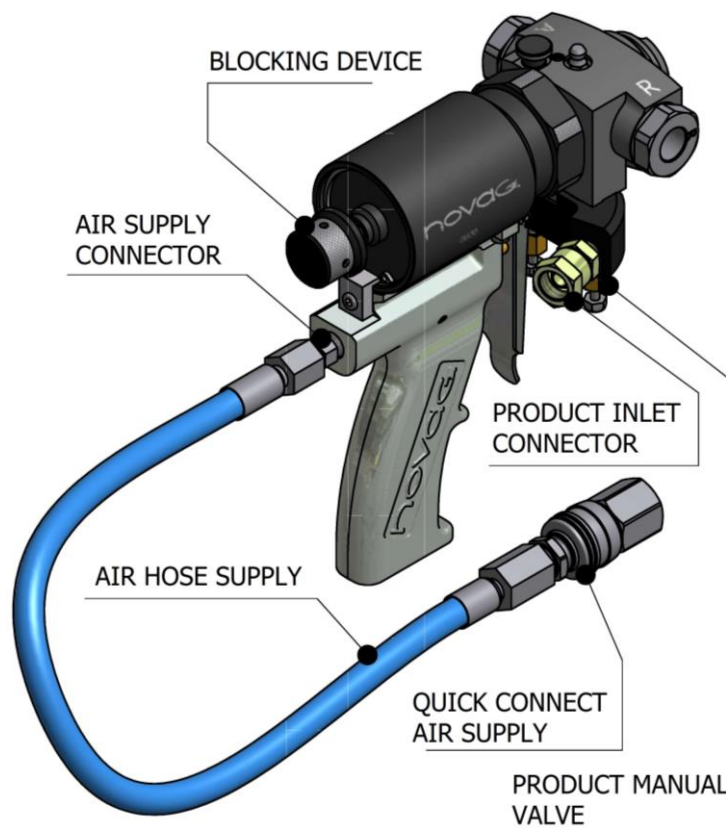

NOTE: The product hoses have been distinguished with red and blue in order to allow them to be rapidly identified. The red corresponds to the Isocyanate hose and the blue corresponds to the Polyol hose. To avoid connection errors, the Isocyanate and Polyol hose coupling connectors are of different sizes, which makes it impossible for connections to be swapped.



5. Open the manual air valve
6. Pressurise the unit and make sure there are no leaks.
7. Activate the trigger several times to make sure the mix chamber moves correctly.
8. Make sure that the pressure in the machine and the temperature of the heaters and the hoses are correct (see the Machine Service Manual).
9. Completely open the manual valves of each product by turning them anti-clockwise.
10. Press the blocking device and turn it anticlockwise to leave it in projection mode or position.
11. Perform a test projection in a vessel

WARNING: Before carrying out maintenance, repair or cleaning work, press the blocking device and turn it clockwise to leave it in blocking position or mode. Always remove the coupling block from the gun, completely close the manual product input valves and disconnect the air supply to avoid any possible accident.



Manual Service

This **novaG-A** model comes with a head turning mechanism so that it can be turned according to the inlet position of the product hoses.

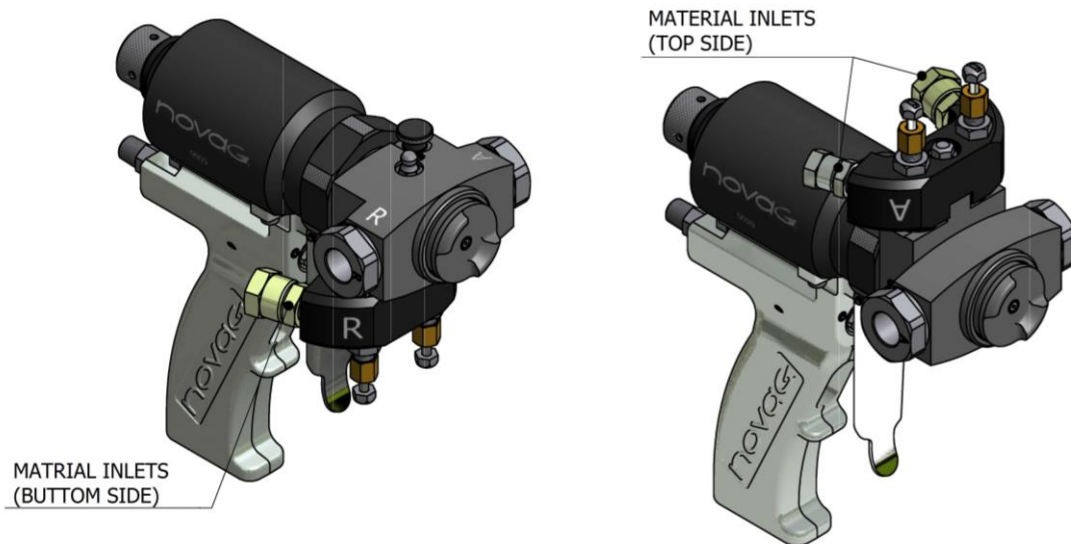

Do the following to make the change:

1. Completely close the manual valves by turning them clockwise.
2. To eliminate the pressure from the gun, press the trigger and project with the gun until the projection fan begins to narrow.
3. Press the blocking device and turn it clockwise to leave it in blocking position or mode.
4. Close the air inlet valve.
5. Remove the coupling block from the gun. Use a cloth dampened in solvent to clean the contact surfaces and the seals of the non-return cartridges.
6. Turn the isocyanate cartridge one turn anticlockwise.
7. Turn the polyol cartridge one turn anticlockwise.
8. Turn the locknut half a turn anticlockwise.
9. Pull lightly on the mix head and turn it 180° (half a turn).
10. Gently press the head until it is seated on the throat of the sleeve and cannot turn. If you do not find the fixing position, leave the head in its theoretical position and tighten the fixing nut slightly.
11. Make sure the head is seated and tighten the sleeve throat fixing nut to fix the head.
12. Tighten the two side cartridges.
13. Connect the coupling block to the mixhead and fix it firmly with the central screw.
14. To leave the gun operative, carry out the following steps for **Installation and Start-up**.

N.B. To pass from one position to another, do not loosen the head fixing nut more than half a turn.



STANDSTILL METHOD

1. Perform the Unit Standstill Method with the procedure indicated in the Machine Service Manual.
2. Completely close the manual valves of each product by turning them clockwise.
3. To eliminate the pressure from the gun, press the trigger and project with the gun until the projection fan begins to narrow.
4. Press the blocking device and turn it clockwise to leave it in blocking position or mode.
5. Remove the coupling block from the gun. Use a cloth dampened in solvent to clean the contact surfaces and the seals of the non-return cartridges.
6. Remove the non-return unit with bottom filter and the friction bushing unit on the Polyol side located in the mixing block or head. Clean the unit with gun cleaning solvent.
7. Remove the non-return unit with bottom filter and the friction bushing unit on the Isocyanate side located in the mixing block or head. Clean the unit with gun cleaning solvent.

NOTE: To remove the check valve and filter cartridges, use a flat screwdriver to lever and remove the assemblies. Be careful not to damage the O-rings. If for any reason, it is not possible to remove the cartridges by this procedure, you can alternatively use a threaded rod or M4 screw, and use them as an extractor.

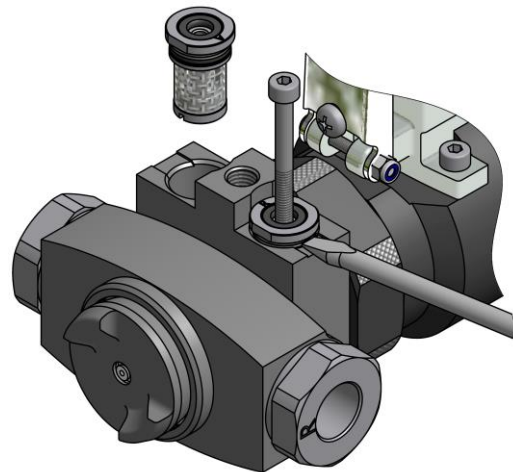

8. Remove the filters. Clean them carefully with gun-cleaning solvent, making sure that the mesh is completely free of product remains.

PRECAUTION: To avoid spilling the rest of the product which has accumulated in the side cartridges and in the non-return cartridges onto the floor, always remove the coupling block and the side cartridges on a waste vessel.

9. Loosen the head by turning the fixing nut anti-clockwise. Turn the head 45° clockwise. Pull on the head to remove it from the gun body. Clean the block with gun cleaning solvent.
10. Remove the diffuser and extract the chamber from the rear of the head.
11. Clean the two contact surfaces of the mix chamber.

PRECAUTION: Use wooden or plastic utensils or a brass brush for cleaning. Do not use metal utensils that can scratch the contact surfaces.

12. Fit all the components and put the coupling block in the gun.



Manual Service

13. Remove the stopper and grease the mix chamber with the greasing pump supplied in the kit with the gun. this will prevent the cleaning air of the gun from drying the ISOCYANATE product, and will therefore prevent it from crystallising and scratching the chamber and the bushing.

NB.: *The action of lubricating the gun at the end of the day will avoid maintenance time, as it will not be necessary to remove the chamber each day to clean it.*

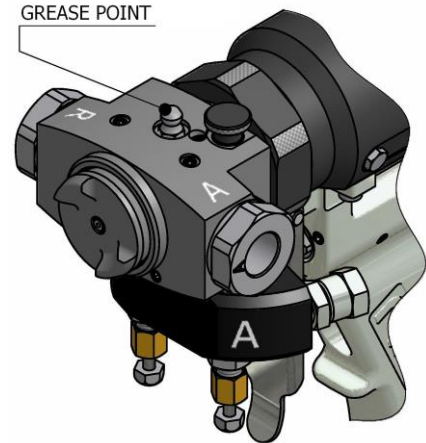

PRECAUTION: *To avoid possible contamination by product remains on the gun components, do not swap Isocyanate parts with Polyol parts. The gun has the Isocyanate side marked with the letter A.*



If the product hoses still have pressure, follow the Standstill Method indicated in the Machine Service Manual.

To eliminate the pressure from the hoses with the gun dismantled, put the product inlet coupling block in a suitable container, remain at a careful distance and very carefully, very slowly open the manual valves. With pressure, the product will come out of the top of the coupling block.



MAINTENANCE

To get the most of your **novaG-A** gun, periodical maintenance must be carried out.



Carefully read the safety data sheet provided by your supplier to prevent any possible injury caused by incorrect handling of the raw materials and solvents used in the process.

Deal with the waste caused according to current regulations.



To prevent serious damage caused by the impact of fluids under pressure, never open a connection or do maintenance work on components subject to pressure until you are sure that all pressure has been eliminated.



Use suitable protection when operating, maintaining or simply being in the area where the equipment is working. This includes, but is not limited to, the use of protective goggles, gloves, shoes and safety clothes and breathing equipment.



The equipment includes components which reach high temperatures and may cause burns. The hot parts of the unit must not be handled or touched until they have completely cooled.

To prevent serious injury caused by crushing or amputations, do not work with the equipment if the moving part safety protections are not duly installed. Make sure that all safety protections are correctly fitted after carrying out repair or maintenance work on the equipment



Gun block unit and mix chamber

WARNING: Before carrying out maintenance work on the gun, make sure that the unit has been completely stopped, that all of the push buttons and the main switch are turned off and that the unit is disconnected from the main power supply. The gun is a component which works under pressure. No connection must be opened or maintenance work be done on component subject to pressure until the pressure has been completely eliminated.

1. Remove the coupling block.
2. Use a cloth dampened in solvent to clean the contact surfaces and the seals of the non-return cartridges.

NOTA: Si por rotura o deterioro debe reemplazar alguno de los grifos, asegúrese que antes de montarlo en el "coupling block" estos estén completamente abiertos (que la esfera quede alojada en el interior del cuerpo del grifo). Si no es así, podría dañar los grifos a la hora del montaje.

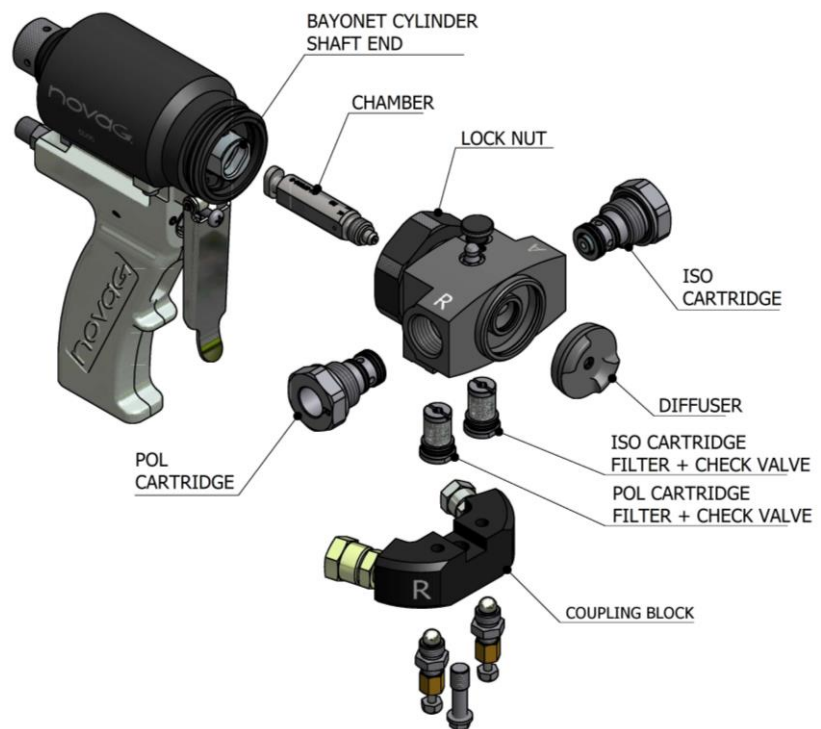

PRECAUTION: To avoid spilling the rest of the product which has accumulated in the cartridges onto the floor, always remove the coupling block and the side cartridges on a waste vessel.



3. Remove the lower check valve cartridges as shown on page 12 with the help of a screwdriver, threaded rod or screw.
4. Loosen the head fixing nut by turning it anti-clockwise and then remove the central block or head by turning it 45° clockwise and pulling on it so that it separates from the rest of the gun. Inspect the o-ring on the fixing nut and replace it if necessary.
5. Unscrew and remove the isocyanate cartridge
6. Unscrew and remove the polyol cartridge
7. Unscrew the diffuser and inspect the internal seal.

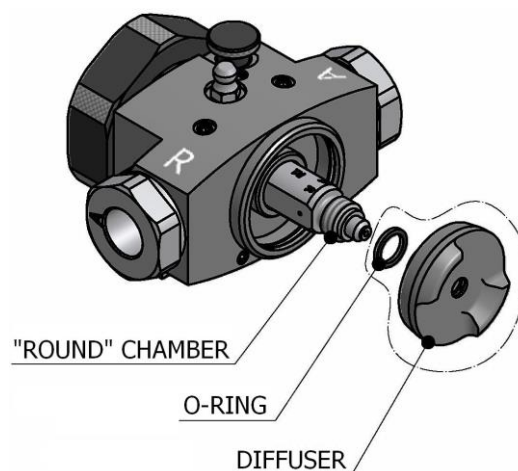

Round Jet Assembly

8. Make sure the air holes for projection are not obstructed. If they are blocked or dirty, clean them with suitable brushes of the right size.

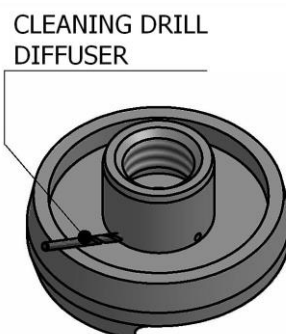

Cleaning "Round" Diffuser Projection Air Holes

N.B.: the diffuser cleaning chucks are attached with it in the spare parts and in the gun tool kit.

9. Remove the mixing chamber from the rear of the head. Inspect it and replace it if it is damaged.



Manual Service

10. To clean the product holes of the chamber, use suitable brushes of the right size for the holes. It is not necessary to remove the head chamber to do this operation.

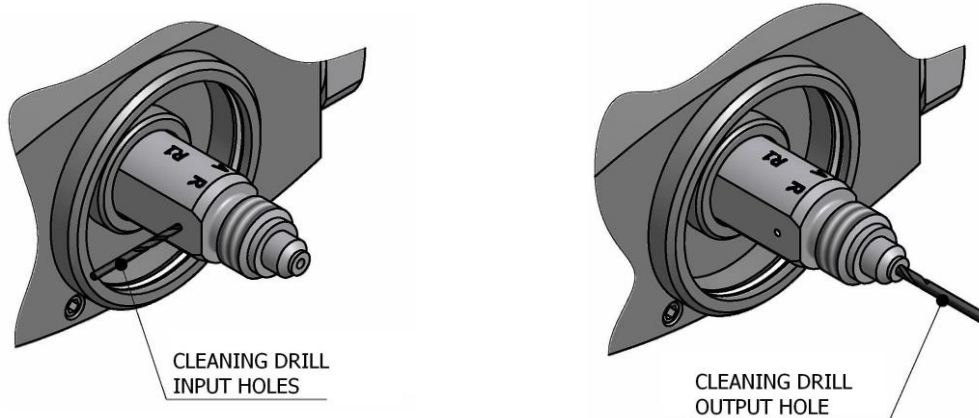

Cleaning "Round" Chamber Product Input Holes

Cleaning "Round" Chamber Product Output Hole

N.B.: the chamber cleaning chucks are attached with them in the spare parts and in the gun tool kit.

11. Put the block in a vessel with gun cleaning liquid.
12. To eliminate all product remains, put the gun block unit in a vessel with gun cleaning liquid and rub it with a brass brush.

PRECAUTION: Use wooden or plastic utensils or a brass brush for cleaning. Do not use metal utensils that can scratch the contact surfaces.

Rearm the gun according to the following procedure:

13. Screw on the friction bushing cartridges by hand, paying attention to the location of each one ("A" ISO side and "R" POL side).



Manual Service

14. Insert the mixing chamber in the head paying attention to its position ("A" ISO side "R" POL side). Make sure the notch on the head of the chamber is always turned to the "A" side ISO.
15. Fit the seal and the PCD if you are working with the "Flat" chamber.
16. Screw the diffuser onto the chamber by hand.
17. Fit the gun block unit or head by inserting the head of the chamber in the housing at the end of the plunger shaft turned 45°.
18. Turn the head until it is in vertical position and push it down so that the positioning grooves fit on to the sleeve.
19. If you fail to find this position, place the head in the theoretical position and lightly press the fixing nut. Make sure the head is unable to turn and tighten the fixing nut.
20. Use a spanner first to tighten the isocyanate cartridge and then the polyol cartridge.
21. Fit the filters and non-return cartridges on the head, paying attention to the location of each one ("A" ISO side and "R" POL side). Take care not to damage the cartridge seals when inserting them on the head (use grease for easier insertion).
22. Fit the coupling block.

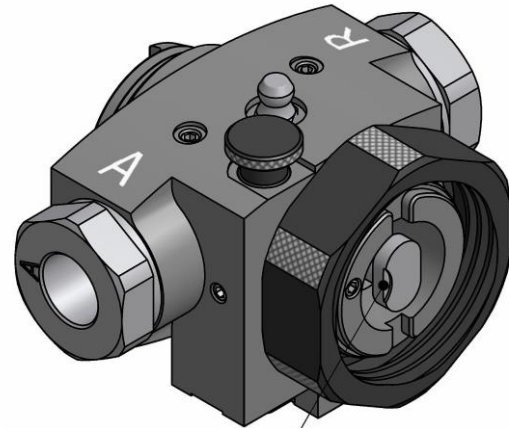

NOTCH HEAD CHAMBER



Manual Service

Side cartridge unit

WARNING: Before carrying out maintenance work on the gun, make sure that the unit has been completely stopped, that all of the push buttons and the main switch are turned off and that the unit is disconnected from the main power supply. The gun is a component which works under pressure. No connection must be opened or maintenance work be done on component subject to pressure until the pressure has been completely eliminated.

1. Perform the Unit Standstill Method with the procedure indicated in the Machine Service Manual.
2. Completely close the manual valves of each product by turning them clockwise.
3. To eliminate the pressure from the gun, press the trigger and project with the gun until the projection fan begins to narrow.
4. Disconnect the air supply from the gun.
5. Unscrew the isocyanate side cartridge by turning it anticlockwise and remove it from its housing. Clean the housing with gun cleaning solvent and make sure no loose particles remain inside.

PRECAUTION! Use wooden or plastic utensils or a brass brush for cleaning. Do not use metal utensils that can scratch the surface.

Before cleaning the cartridge housing and contact bushing with cleaning fluid, remove all of the o-rings in these components to avoid them being damaged by the cleaning fluid or the brass brush.

6. Check the seals of the cartridge and the contact bushing. Replace them if they are worn or damaged.
7. Check the metal friction bushing for wear and measure its complete length. Replace it if the length is under 7 mm.
8. Grease all of the components and refit them in the cartridge.
9. Screw the isocyanate cartridge unit into its housing until it blocks. Make sure it is correctly tightened to avoid product leaks.
10. Do the same with the polyol cartridge. (points 5-9).
11. Carry out the projection procedure indicated in the start-up section.
12. Start the gun.

PRECAUTION: Use wooden or plastic utensils or a brass brush for cleaning. Do not use metal utensils that can scratch the contact surfaces.

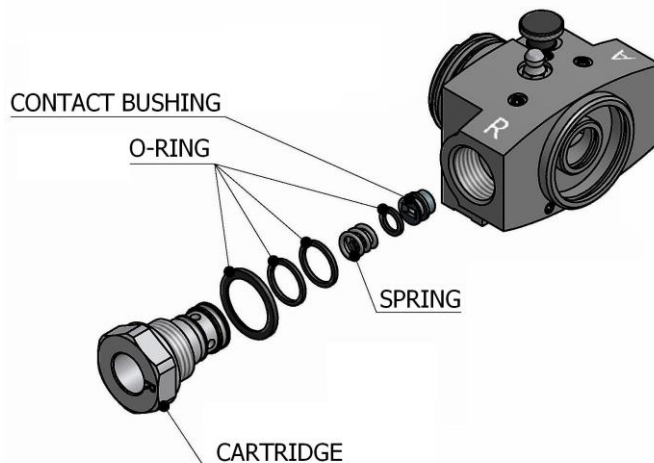



Filter and Non-Return cartridge unit

WARNING: Before carrying out maintenance work on the gun, make sure that the unit has been completely stopped, that all of the push buttons and the main switch are turned off and that the unit is disconnected from the main power supply. The gun is a component which works under pressure. No connection must be opened or maintenance work be done on component subject to pressure until the pressure has been completely eliminated.

1. Perform the Unit Standstill Method, following the procedure indicated in the Machine Service Manual.
2. Completely close the manual valves of each product by turning them clockwise.
3. To eliminate the pressure from the gun, press the trigger and project with the gun until the projection fan begins to narrow.
4. Disconnect the air supply from the gun.
5. Remove the lower check valve cartridges as shown on page 12 with the help of a screwdriver, threaded rod or screw.
6. Unscrew the stopper and remove the spring and the non-return ball. Clean them with gun-cleaning solvent.

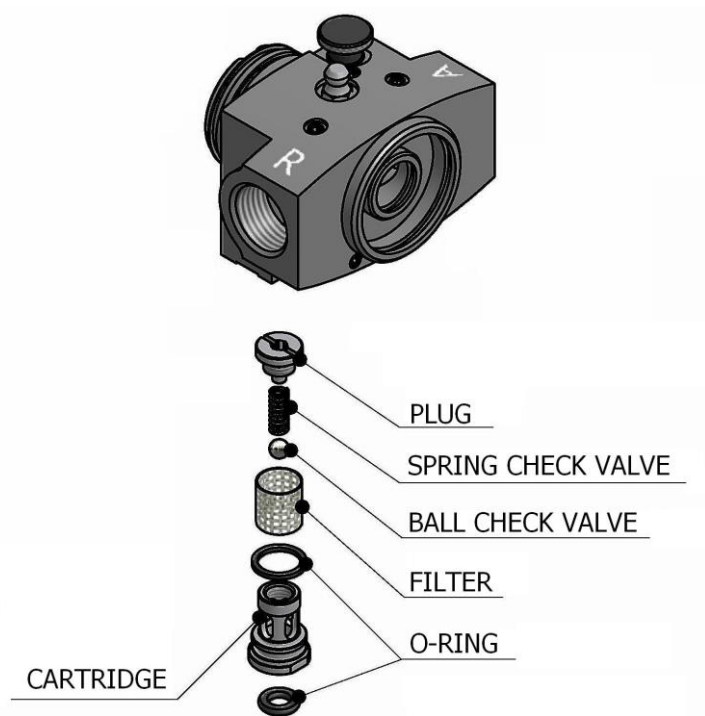

7. Separate the filter and clean it with gun cleaning solvent. Make sure that it is not blocked. If you see that the mesh is obstructed over more than 20% of its filter surface, replace it.
8. Clean all of the components meticulously to eliminate all product remains using a cloth dampened with gun cleaning solvent and a brass brush.
9. Make sure the holes of the filter holder cartridge are not blocked by remains of crystallised product. If you should see any dirt on the head, clean the communicating drill holes with a drill and a brass brush.



Trigger and valve

WARNING: Before carrying out maintenance work on the gun, make sure that the unit has been completely stopped, that all of the push buttons and the main switch are turned off and that the unit is disconnected from the main power supply. The gun is a component which works under pressure. No connection must be opened or maintenance work be done on component subject to pressure until the pressure has been completely eliminated.

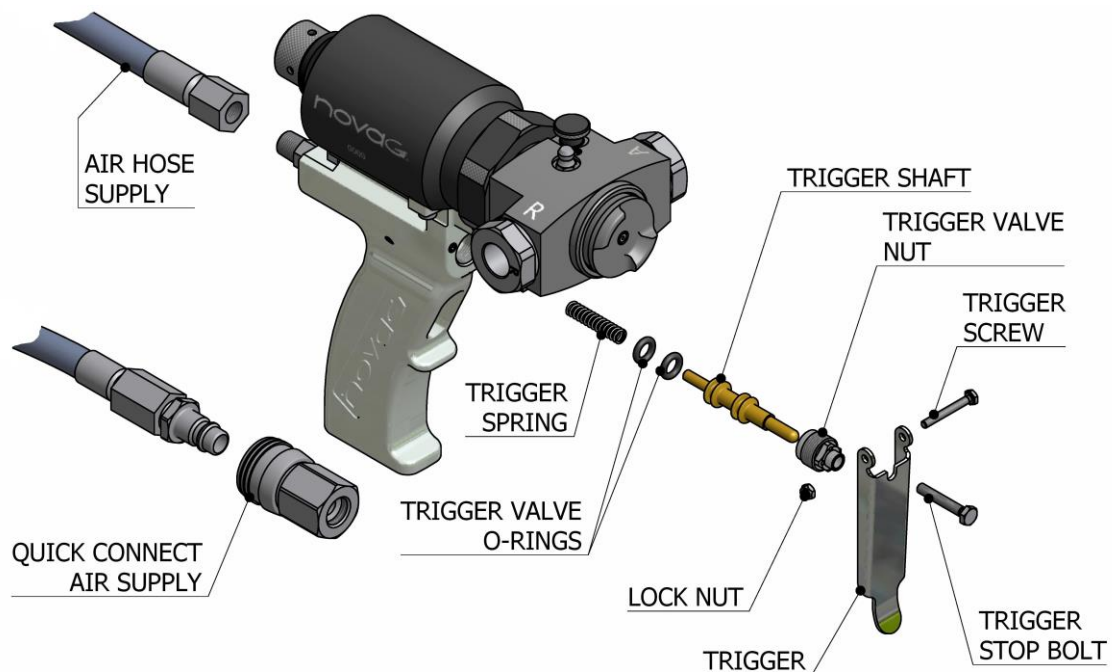

1. Remove the coupling block.
2. Use a cloth dampened in cleaning fluid to clean the contact surfaces and the seals of the non-return cartridge bases.
3. Disconnect the air pipe.
4. Remove the trigger stop screw.
5. Remove the retention nut and extract the screw holding the trigger.
6. Unscrew the nut of the trigger valve.
7. Remove the trigger shaft and carefully hold it by the end with pliers to remove it from its housing. The trigger shaft has a spring in the base. Make sure you do not lose it.
8. Check the o-rings of the trigger shaft. Replace them if they are damaged. Apply a little grease to make it easier to assemble.



9. Make sure the trigger shaft housing is clean and apply a small layer of grease inside.
10. Fit the air hose to the rear of the gun with sealing paste on the thread to avoid air leaks.
11. Insert the trigger shaft in the spring and insert it inside the grip taking special care not to damage the o-rings. You will note a certain resistance caused by the interference of the seals with the housing wall.
12. Screw on the trigger valve nut until it comes up against the base.
13. Fit the trigger with the screw and hold it with the retention nut.
14. Fit the trigger stop screw. Screw it to eliminate the play in the trigger (without moving the shaft).
15. Fix the mixing block according to the procedure described in the pistol block unit and mix chamber assembly section.
16. Start the gun.



Cylinder block and blocking device

WARNING: Before carrying out maintenance work on the gun, make sure that the unit has been completely stopped, that all of the push buttons and the main switch are turned off and that the unit is disconnected from the main power supply. The gun is a component which works under pressure. No connection must be opened or maintenance work be done on component subject to pressure until the pressure has been completely eliminated.

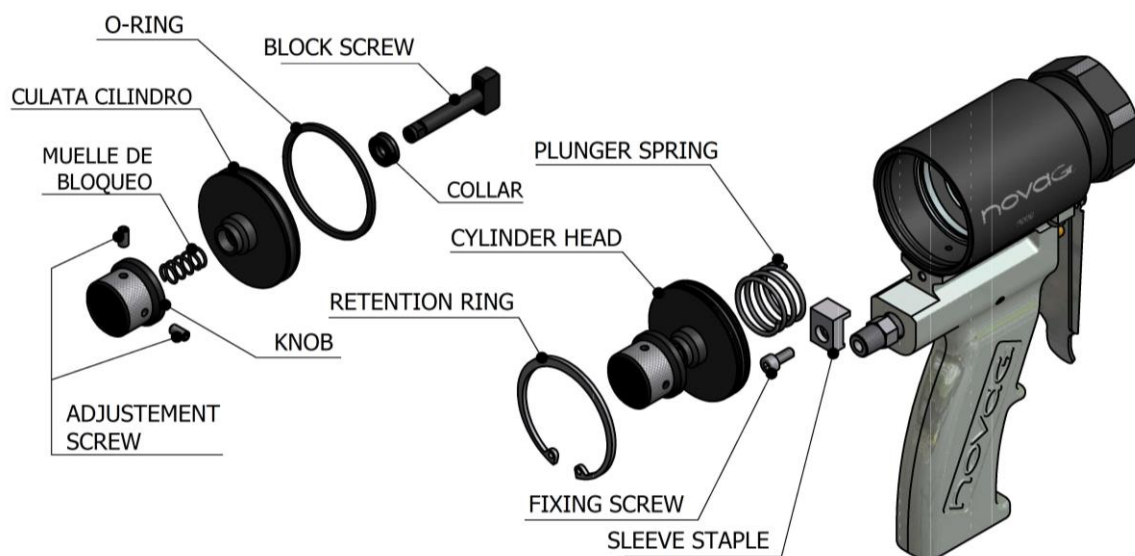

1. Unscrew the bolt fixing the lining pin on the rear of the gun.
2. Remove the retention ring positioning the cylinder block, using pliers for seeger rings.
3. Pull hard on the blocking device to remove the whole unit from the cylinder sleeve. Also remove the plunger spring.
4. Check the state of the closing seal of the cylinder block. Replace it if it is damaged.
5. Apply a little grease to make it easier to assemble.
6. Loosen the two adjustment screws on the blocking device. Remove the blocking screw and the blocking spring from the device.
7. Separate the cylinder block from the blocking screw.
8. Remove the collar from the cylinder block and replace it if it is damaged. Apply a little grease to make it easier to assemble.
9. Pay special attention to correctly fit the collar: **the closing lips must face the cylinder side.**



10. Fit the cylinder block on the blocking screw. Slip the spring and the blocking device on the blocking screw. Screw in the two adjustment screws, making sure that they are perfectly flush with the flats at the end of the blocking screw. Make sure that the blocking device is well-fitted.
11. Insert the spring in the rear housing of the plunger. Insert the cylinder block unit in the lining, pressing until it passes the insertion groove of the retention ring.
12. Fit the retention ring, using pliers for seeger rings.

WARNING: *To guarantee that the cylinder block is correctly fixed, make sure that the retention ring is perfectly housed in the fixing groove. To avoid any possible error in assembly, avoid approaching the cylinder block when pressure is applied to the gun after performing any cleaning, repair or maintenance work.*

13. Fit the sleeve staple and fix it with the screw to the rear of the gun.
14. Start the gun.

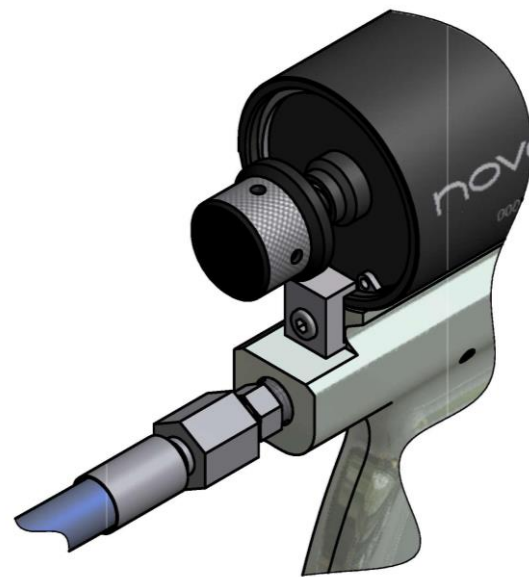



Pneumatic cylinder

WARNING: Before carrying out maintenance work on the gun, make sure that the unit has been completely stopped, that all of the push buttons and the main switch are turned off and that the unit is disconnected from the main power supply. The gun is a component which works under pressure. No connection must be opened or maintenance work be done on component subject to pressure until the pressure has been completely eliminated.

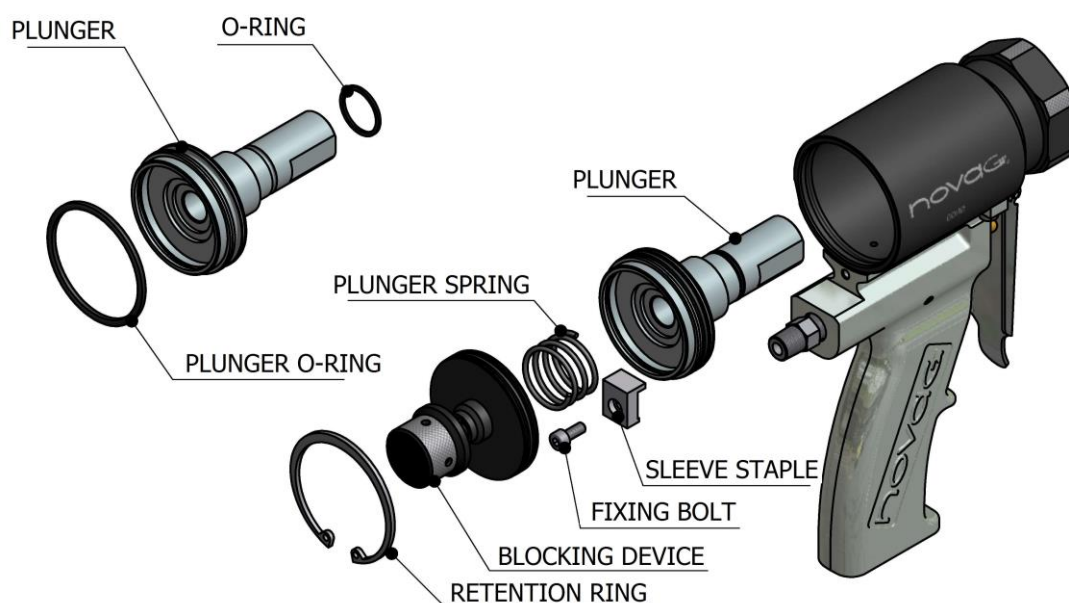

1. Proceed to remove the mix chamber following the procedure indicated in the **Gun block unit and mix chamber** section. Clean the mix chamber and, if you consider it necessary, use a brush to go over the passage holes.
2. Unscrew the bolt fixing the lining pin on the rear of the gun.
3. Remove the retention ring positioning the cylinder block, using pliers for seeger rings.
4. Pull hard on the blocking device to remove the whole unit from the cylinder sleeve. Also remove the spring and the plunger from inside the cylinder.
5. Check the state of the o-rings of the shaft and the plunger. Replace them if they are damaged. Apply a little grease to make it easier to assemble.
6. Fit the plunger inside the cylinder sleeve taking special care not to damage the o-rings.
7. Insert the spring in the rear housing of the plunger. Insert the cylinder block unit in the lining, pressing until it passes the insertion groove of the retention ring.
8. Fit the retention ring, using pliers for seeger rings.



WARNING: To guarantee that the cylinder block is correctly fixed, make sure that the retention ring is perfectly housed in the fixing groove. To avoid any possible error in assembly, avoid approaching the cylinder block when pressure is applied to the gun after performing any cleaning, repair or maintenance work.

9. Fit the sleeve staple and fix it with the screw to the rear of the gun.
10. Fix the mixing block or head according to the procedure described in the pistol block unit and mix chamber assembly section.
11. Make sure you fit the o-ring between the block and the sleeve, replacing it if it is damaged.
12. Start the gun.

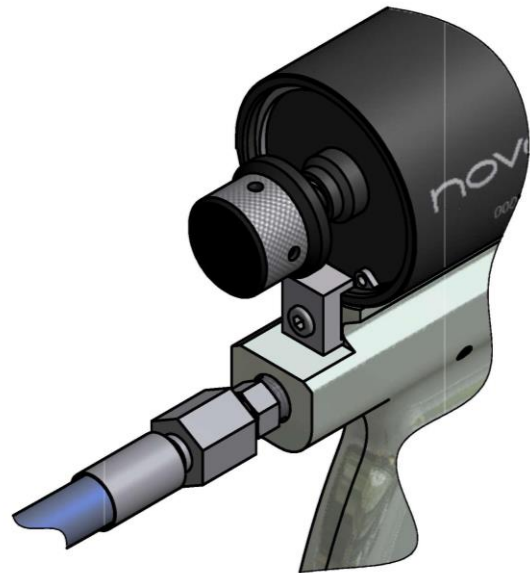



CONTENT

Warranty	2
Safety and Handling	3
Characteristics	6
Specifications	6
General Description	7
Method of Threaded Union of the Hoses	8
Installation and Start-up	9
Standstill Method	12
Maintenance	14
Gun block unit and mix chamber	15
Side cartridge unit	19
Filter and Non-Return cartridge unit	20
Trigger and valve	21
Cylinder block and blocking device	23
Pneumatic cylinder	25
Content	27