



Service Manual

Spray Unit

novaG - I

Issue 1.7 18/08/22
Ref. NR-00031-ENG



Before preparing the unit and starting it up, please take the time to read all the technical and safety instructions in this manual. It is essential that you follow these instructions carefully so that you can handle and use the unit properly. These instructions are intended to maximize user safety and avoid malfunctions deriving from the incorrect use of the unit.



WARRANTY

HI-TECH SPRAY EQUIPMENT, S. A. (hereinafter "HI-TECH") grants this Limited Guarantee to the original buyer (hereinafter the "Client") for the unit and the original accessories given with the unit (hereinafter the "Product") against any fault in the design, materials or manufacture of the Product at the time of the first purchase by the user and for a duration of two (2) years thereafter.

If during the guarantee period and under normal conditions of use, the Product should fail to work correctly due to defects of design, material or manufacture, the authorised distributor of the country where the HI-TECH Product or technical assistance service has been purchased shall repair or replace the Product in accordance with what is established in the following:

CONDITIONS

- a) The validity of this guarantee will be subject to the presentation of the original invoice issued by the HI-TECH authorised distributor for the sale of the Product along with the Product handed over for repair or replacement, which must show the date of purchase and the serial number. HI-TECH reserves the right to refuse to give the guarantee service when the indicated data fail to appear on the invoice or have been modified after the purchase of the Product.
- b) The repaired or replaced Product will continue to maintain the original guarantee for the time remaining until the end of the guarantee or for three (3) months from the repair date, if the remaining period of the original guarantee were shorter.
- c) This guarantee will not be applied to the faults in the Product caused by its faulty installation, the natural wear and tear of the components, any use other than that considered normal for this Product or which should fail to strictly comply with the instructions of use provided by HI-TECH; due to accident, carelessness, adjustments, alterations or modifications of the Product not authorised by HI-TECH or due to the use of accessories, heating devices, pumping equipment and/or dispensers that have not been approved or manufactured by HI-TECH.
- d) The guarantee applicable to the components and accessories forming part of the Product and which have not been made by HI-TECH will be limited to the guarantee offered by the original manufacturer thereof.

HI-TECH WILL NOT RECOGNISE ANY EXPRESS ORAL OR WRITTEN GUARANTEES OTHER THAN THIS PRINTED LIMITED GUARANTEE. ALL IMPLICIT GUARANTEES, INCLUDING, WITHOUT LIMIT, ADAPTATION FOR A SPECIFIC USE, ARE SUBJECT TO THE DURATION OF THIS WRITTEN GUARANTEE. HI-TECH DOES NOT ASSUME ANY KIND OF COMMITMENT OR RESPONSIBILITY FOR ALL POSSIBLE DAMAGE OR EXPENSE CAUSED BY FAULTS IN THE OUTPUT OF THE PRODUCT, ITS WORKING OR THE DISPENSING OF MATERIAL THROUGH THE PRODUCT, INCLUDING, WITHOUT LIMITATION, ALL EXPENSES CAUSED BY DAMAGE TO PEOPLE OR PROPERTY. EQUALLY, HI-TECH WILL IN NO CASE ACCEPT LIABILITY FOR THE LOSS OF SPECULATIVE PROFITS OR COMMERCIAL LOSSES. ALL REPAIRS OR REPLACEMENT OF FAULTY PRODUCTS WILL CONSTITUTE THE COMPREHENSIVE FULFILMENT OF HI-TECH'S OBLIGATIONS WITH RESPECT TO THE CLIENT. HI-TECH DOES NOT IN ANY WAY GUARANTEE THE SUITABILITY OR APTITUDE OF ITS PRODUCT FOR ANY PARTICULAR PURPOSE OR APPLICATION.

All information provided on components which have not been manufactured by HI-TECH and which is based on reports received from the original manufacturer, though considered precise and reliable, is provided without any guarantee or responsibility of any explicit or implicit kind.

All concession, sale or financial leasing of the Product by HI-TECH in no case explicitly or implicitly constitutes any authorisation, acceptance or concession for the use of any rights or patents, nor does it encourage, nurture or back their infringement.

The restrictions on the guarantee suppose no limitation on the legal rights of the consumer established in applicable national legislation, nor do they affect any rights derived from the bargain and sale agreement between the consumer and supplier.

All information provided in this manual has been included in the confidence that it is true, although it does not constitute any responsibility or implicit or explicit guarantee. HI-TECH reserves the right at any time and without prior warning to make all improvements and modifications necessary to this manual, in order to rectify any possible typographical errors, increase the information contained or insert the changes caused to the characteristics and performance of the unit.



SAFETY AND HANDLING

The equipment described in this manual has been designed and manufactured in compliance with the following European Directives, following as application guide the harmonized standards detailed and in conformity with the relevant UK Statutory Instruments (and their amendments):

Directive 2006/42/EC on machinery (UK Supply of Machinery (Safety) Regulations 2008)

UNE EN 12100:2012 (BS EN ISO 12100:2010)

Directive 2014/30/EU on electromagnetic compatibility (UK Electromagnetic Compatibility Regulations 2016)

UNE EN 55011 (BS UNE EN 55011)

UNE EN 55016-2-1 (BS UNE EN 55016-2-1); UNE EN 55016-2-3 (BS UNE EN 55016-2-3);
UNE EN 55032 (BS UNE EN 55032)

UNE EN 61000-3-2 (BS UNE EN 61000-3-2); UNE EN 61000-3-3 (BS UNE EN 61000-3-3);
UNE EN 61000-4-2 (BS UNE EN 61000-4-2); UNE EN 61000-4-3 (BS UNE EN 61000-4-3);
UNE EN 61000-4-4 (BS UNE EN 61000-4-4); UNE EN 61000-4-5 (BS UNE EN 61000-4-5);
UNE EN 6100-4-6 (BS UNE EN 6100-4-6); UNE EN 61000-4-8 (BS UNE EN 61000-4-8); UNE
EN 61000-4-11 (BS UNE EN 61000-4-11)

Directive 2014/68/EU on pressure equipment (UK Pressure Equipment (Safety) Regulations 2016)

UNE EN 809:1999 +A1 (BS EN 809:1998 +A1:2009)

Directive 2014/35/EU on electrical safety (UK Electrical Equipment (Safety) Regulations 2016)

UNE EN 60204-1:2019 (BS EN 60204-1:2018)

Directive 2003/10/EC on noise level (UK The Control of Noise at Work Regulations 2005)

UNE EN ISO 3740 (BS EN ISO 3740:2019)

UNE EN ISO 3746 (BS EN ISO 3746:2010)

Directive 2011/65/EU on the restriction of the use of certain hazardous substances in electrical and electronic equipment with amendment 2015/863/EU (UK The Restriction of the Use of Certain Hazardous Substances in Electrical and Electronic Equipment Regulations 2012)

Directive 2012/19/EU on waste electrical and electronic equipment (UK The Waste Electrical and Electronic Equipment Regulations 2013)



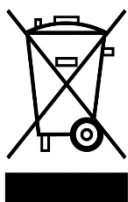

Electrical products cannot be thrown out with the rubbish. They must be taken to a dedicated collection point for an environmentally sound disposal in accordance with local regulations. You must contact your local collective or retailer for information about recycling. Before leaving WEEE at appropriate collection facilities, batteries must be removed and disposed of separately for proper recycling. The packaging materials are recyclable. Dispose of packaging materials in an environmentally sound manner and place them at the disposal of recycling

sectors.

TRANSPORT AND STORAGE

Proper precautions must be taken so that the equipment can withstand the effects of transport and storage temperatures between -25°C and $+55^{\circ}\text{C}$ or up to $+70^{\circ}\text{C}$ for short periods that do not exceed 24 hours. Also, appropriate means to prevent damage from moisture, vibrations or shocks must be foreseen.

This section contains important information on the safe handling and operation of the **novaG - I** proportioning unit.



Before preparing the unit and starting it up, please take the time to read all the technical and safety instructions in this manual. It is essential that you follow these instructions carefully so that you can handle and use the unit properly. These instructions are intended to maximize user safety and avoid malfunctions deriving from the incorrect use of the unit.

A **DANGER!** indication alerts you to situations which may result in serious injury if the instructions are not followed.

A **WARNING!** indication gives information on how to avoid damaging the unit and situations likely to cause minor injury.

A **NOTE** indication provides useful information on the procedure in question.

Read this manual carefully to familiarize yourself with the unit's characteristics and operating procedures. By following the instructions and recommendations contained in this manual you will reduce the risk of accidents in the preparation, use and maintenance of the unit, ensuring incident-free operation for a longer time, improved performance and the quick and easy detection of problems.

Keep this Service Manual handy for reference at all times. If you lose this manual, ask for a new copy from your local **HI-TECH** distributor or directly contact **HI-TECH Spray Equipment, S.A.**

WARNING! *The novaG - I proportioning unit is not designed for use in potentially explosive environments. Pressure and temperature must not exceed the limits indicated in the technical specifications of this manual.*



Service Manual

When working with the unit, it is essential that you wear suitable clothing and personal protective equipment including but not limited to gloves, protective goggles, safety footwear and face masks. Use breathing equipment when working with the unit in enclosed spaces or in areas with insufficient ventilation. The safety measures given in in this manual are part of a wider safety procedure. Before powering up the unit, you must perform a comprehensive analysis of the risks associated with the products it dispenses, the type of application, and the working environment.



To avoid bodily damage caused by the incorrect handling of the substances and solvents used with this unit, read carefully the safety information provided by their suppliers.

Dispose of waste as required by applicable legislation.



Disconnect the unit from the power supply before opening the electrical console.

Electrical maintenance should only be carried out by a qualified electrician.



To avoid exposure to pressurized fluids, do not release any connectors or perform maintenance work on parts subjected to pressure until the pressure has been completely eliminated.

Use suitable protection when using or performing maintenance on the unit, or when in its vicinity. This protection includes, but is not limited to, the use of masks, protective goggles, gloves, safety footwear and safety clothing.



This unit includes parts which reach temperatures likely to cause burns. Do not touch or handle the hot parts of the unit until they have cooled down.



To avoid the risk of crushing or amputation, only use this unit when its moving parts are fitted with correctly installed safety guards. Make sure all safety guards are correctly mounted after completing repair or maintenance work.



CHARACTERISTICS

The **novaG - I** proportioning unit is designed for the application of polyurea chemical systems for polyurethane foaming and certain two-component epoxy systems.

Principal heating system

Consists of two independent heaters without gaskets. Each heater has two 900 W heating elements delivering total power of 1800 W, and the necessary control and safety mechanisms for the correct operation of the system. Their special configuration permits a temperature differential (ΔT) of 30° C and application temperatures of 80°C under normal ambient temperature conditions.

Hose heating system

The unit features two systems for keeping the products hot while in the hoses:

- Recirculation hoses (maximum length 11 metres)
- Hose heated by woven elements at 230V fitted with temperature sensor (maximum length 20 metres)

If longer hoses are required, a standard HI-TECH hose (maximum length 48 metres) heated by transformer can be used.

Proportioning pumps

This assembly comprises two positive-displacement piston pumps operated by a dual-piston hydraulic cylinder.

The parallel piston pump configuration ensures constant volume and guarantees uniformity of pressure in both directions of pump movement.

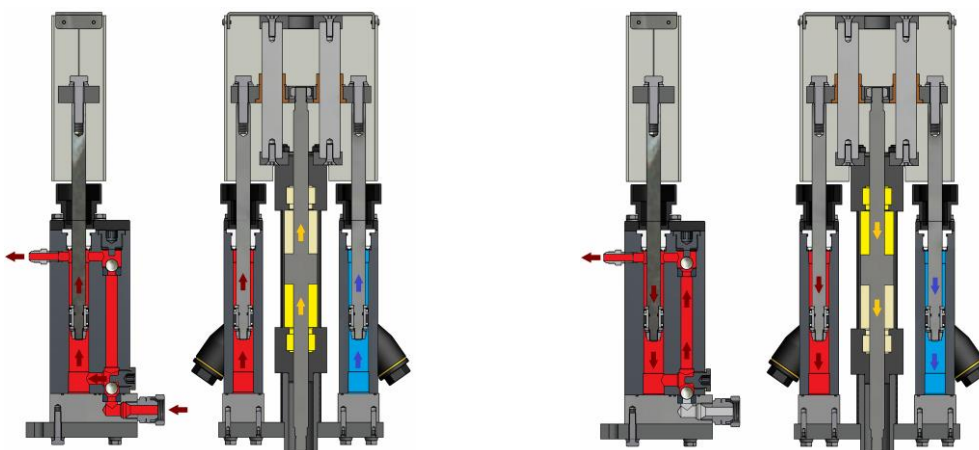



TECHNICAL SPECIFICATIONS

Electrical

Voltage: _____ 230V

Frequency: _____ 50/60Hz

Connections 1 and 2: _____ 2x1NPE~230 V /1x 3NPE~400 V

Connection 1 power consumption: _____ 3,3 kW (1,8 kW motor + 1,5 kW hoses)

Connection 2 power consumption: _____ 3,6 kW (heaters)

Connection 1 consumption: _____ 16A

Connection 2 consumption: _____ 16A

Frequency Transformer (Optional): _____ 50/60Hz

Transformer Connections (Optional): _____ 1NPE~230V / 1NPE~400V

Active Power Transformer (Optional) : _____ 1,6 kW

Mechanical

Maximum working pressure: _____ 170 bar (17 MPa)

Maximum output at 1:1 ratio: _____ 4 kg/min

Minimum output: _____ 1 kg/min

Length of recirculation hose: _____ 11 m

Maximum heated hose length (230V): _____ 20 m

Maximum heated hose length with transformer (optional): _____ 48 m

Recommended compressor: _____ 1 HP single-phase

Approximate weight: _____ 165 kg

Dimensions: _____ H: 1228 mm / W: 605 mm / D: 819 mm

Acoustic

A-weighted sound pressure level: _____ 79,2 dB (A)

A-weighted sound power level: _____ 94,0 dB (A)

Values obtained according to UNE-EN ISO 3746:1995 standard.

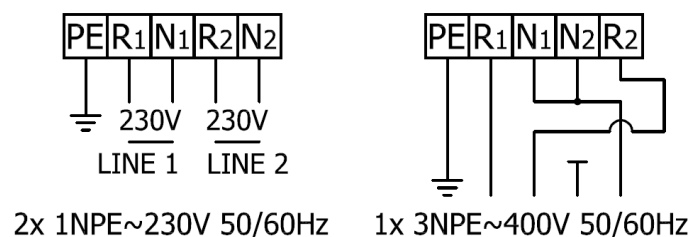



OVERVIEW

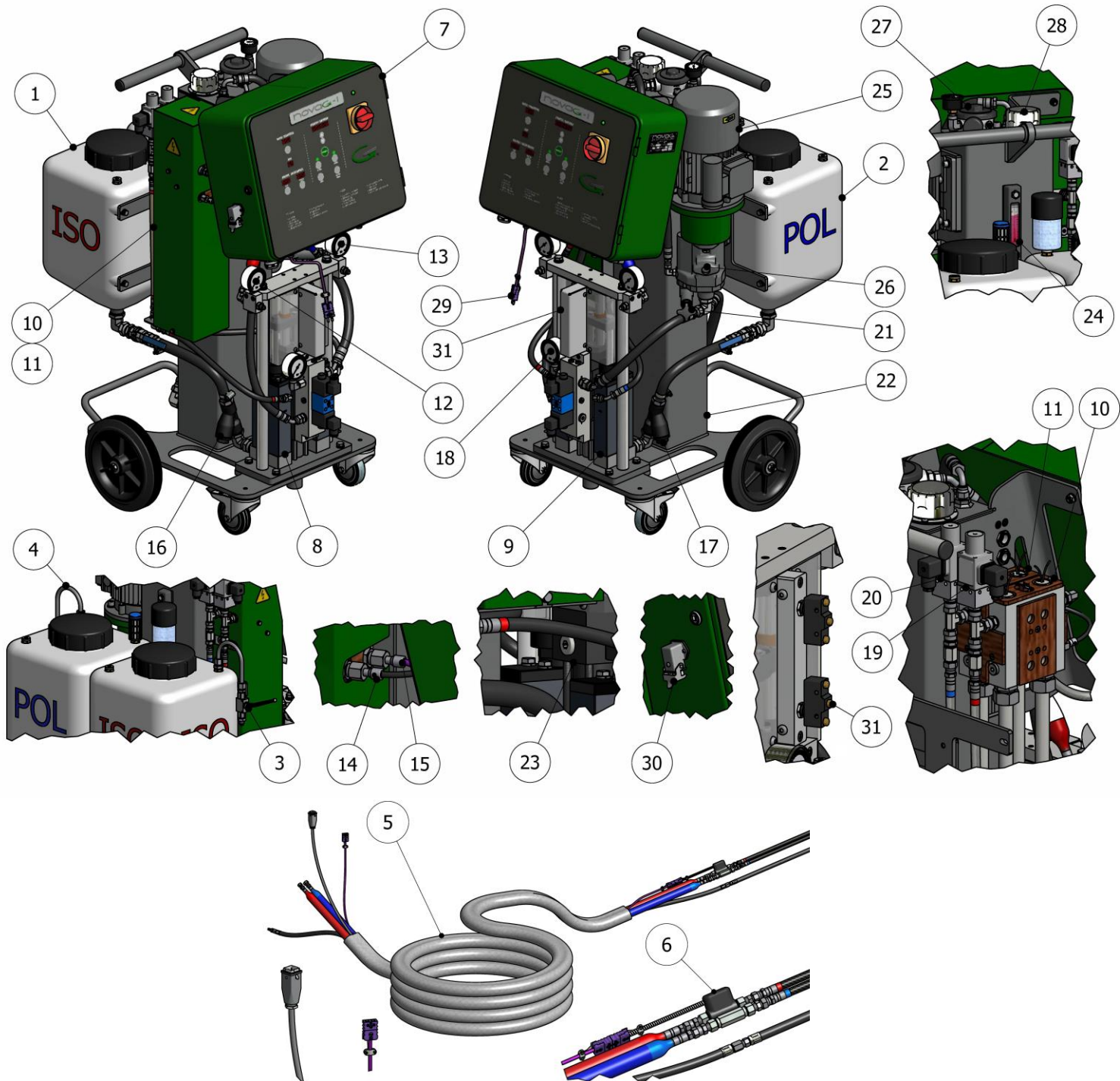

Figure 1. General view



Service Manual

1. Isocyanate tank

Contains chemical component "A". Capacity 30 litres.

2. Polyol tank

Contains chemical component "R". Capacity 30 litres.

3. Isocyanate recirculation valve (recirculation hoses only)

Enables selection between recirculation and spray for the isocyanate circuit.

4. Polyol recirculation valve (recirculation hoses only)

Enables selection between recirculation and spray for the polyol circuit.

5. Hoses with built-in heating 230V (optional)

Keeps spray products at the right temperature.

6. Hose temperature sensor (heated hoses only)

Monitors the temperature of the spray products.

7. Control panel

Controls the correct operation of the unit.

8. Isocyanate proportioning pump

Delivers metered quantities of isocyanate to the system.

9. Polyol proportioning pump

Delivers metered quantities of polyol to the system.

10. Isocyanate heater

Heats the isocyanate to the pre-set temperature.

11. Polyol heater

Heats the polyol to the pre-set temperature.

12. Isocyanate pressure gauge

Indicates the pressure in the isocyanate circuit.

13. Polyol pressure gauge

Indicates the pressure in the polyol circuit.

14. Isocyanate heater sensor

Provides information on the temperature of the isocyanate heater.

15. Polyol heater sensor

Provides information on the temperature of the polyol heater.

16. Isocyanate intake filters

Prevent solid particles from the entering the unit's isocyanate pump.

17. Polyol intake filters

Prevent solid particles from the entering the unit's polyol pump.

18. Hydraulic pressure gauge

Indicates the pressure of the hydraulic circuit.

19. Isocyanate circuit safety pressure switch

Shuts off the solenoid valve in the event of excess pressure in the isocyanate circuit.

20. Polyol circuit safety pressure switch

Shuts off the solenoid valve in the event of excess pressure in the polyol circuit.



Service manual

21. Hydraulic pressure regulator

Enables the pressure of the hydraulic circuit to be increased or reduced.

To increase pressure, turn the tap clockwise; to reduce pressure, turn the tap anti-clockwise.

NORMAL or RETRACT commands must be active before you can adjust the pressure of the hydraulic circuit.

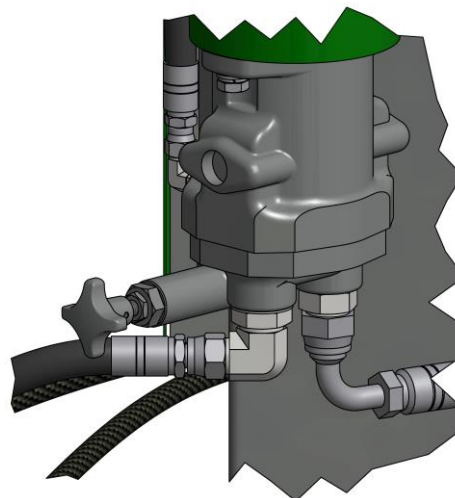

The hydraulic circuit should be regulated to ensure that the unit's output pressure never exceeds the working pressure of the product hoses fitted to the unit.

22. Hydraulic oil tank

Contains the oil used by the unit's hydraulic system.

23. Hydraulic cylinder

Drives the pumps.

24. Oil level and thermometer

Displays the fluid level and temperature of the hydraulic oil tank.

25. Electric motor

Drives the hydraulic pump.

26. Hydraulic pump

Axial piston pumps are swash plate design variable displacement pumps.

The flow and pressure compensator control, also known as a load sensing control, matches pump output flow and pressure to the system demand.

Pumps oil to the hydraulic cylinder.

27. Hydraulic return filter

Filters impurities from the hydraulic oil.

28. Hydraulic oil fill cap

For topping up the oil tank.

29. Male connector hose heating

Allows temperature control in the hoses.

30. Heated hose connector

Provides the necessary voltage for heating the hoses.

31. Reversing switch

Actuate to change of direction of the hydraulic cylinder.



Service Manual

32. TCS DIP switches

Enables selection of the hose heater control mode depending on whether hoses incorporate a temperature control sensor (TCS). See page 11 point 2 of this manual for instructions on selecting the correct control mode. ***The unit must be disconnected before operating the DIP switch.***



33. Temperature units DIP switch

Enables selection of temperature units on the control panel displays. Set this switch to the "EU" position to display the temperature in degrees Celsius (°C), or "USA" to display the temperature in degrees Fahrenheit. ***The unit must be disconnected before operating the DIP switch.***



34. Motor DIP switch

Activates/deactivates the hydraulic drive. Factory settings depend on the model. ***The "Motor DIP" selector function is only active in units with hydraulic drive. The unit must be disconnected before operating the DIP switch.***



CONTROL PANEL

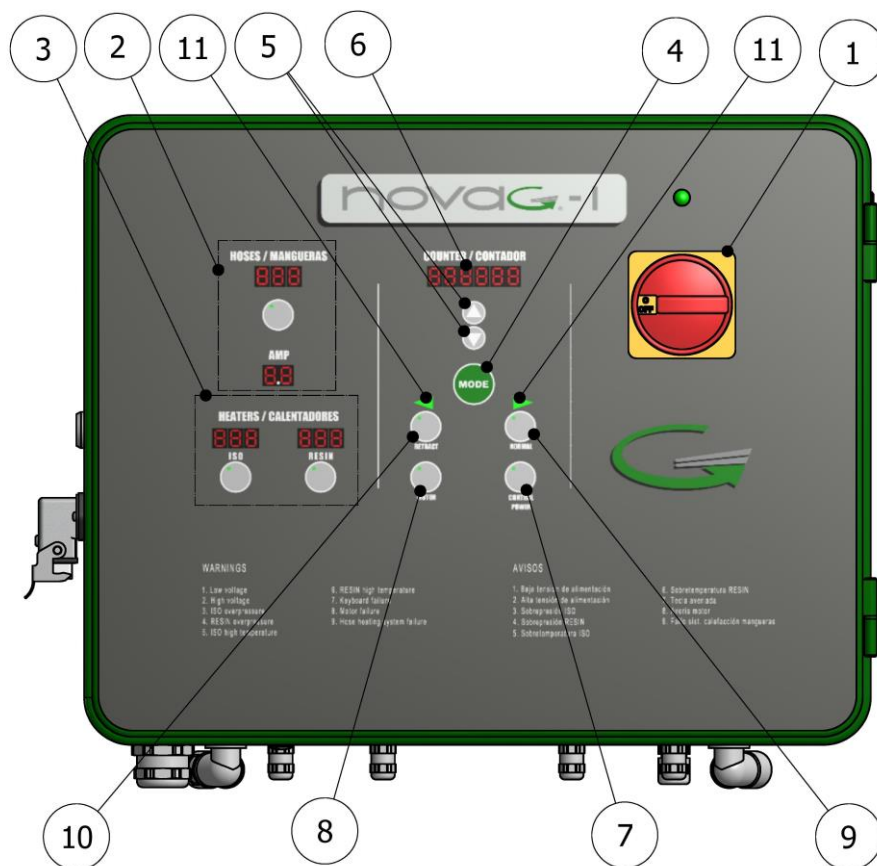

Figure 2. Control panel

The control panel enables you to set the optimum operating conditions for the characteristics and requirements of the products dispensed. Press the MODE button to enter the desired settings for temperature, intensity and number of cycles to run. The selected parameter remains flashing for a few seconds, allowing you to change the values by touching the UP / DOWN buttons. After changing the value, press the MODE button again to confirm your selection.

The parameter modification function automatically cancels after a few seconds if there is no further activity on the buttons.

The parameters that can be selected and viewed are:

- Hose temperature in automatic control mode (maximum 80°C)
- Hose heating intensity in manual control mode (maximum 5.0 amps)
- Isocyanate heater temperature (maximum 90°C)
- Polyol heater temperature (maximum 90°C)
- Number of cycles to run.
- Number of cycles completed.



Service Manual

1. Power switch

Connects and disconnects the unit from the electricity supply. This switch must be in the ON position for the unit to work. When this switch is in the ON position, the green pilot light above the switch lights up.

2. Hoses / Mangueras

Hose heating control (OPTIONAL) can be automatic when a temperature control sensor is used for direct temperature control, or manual where no temperature control sensor is used. The control mode is selected via a DIP switch on the printed circuit board. Set the "HOSE TEMP" DIP to ON if the isocyanate hose incorporates a temperature control sensor. If the isocyanate hose does not incorporate a temperature control sensor, or if it is not working due to malfunction or other reasons, set the DIP to OFF.



In automatic control mode, the temperature in the isocyanate (ISO) hose is shown on the corresponding display. In manual control mode, only the selected amperage value is shown.

The unit must be disconnected before operating the DIP selector.

HOSE TEMP ON

with temperature control sensor in ISO hose

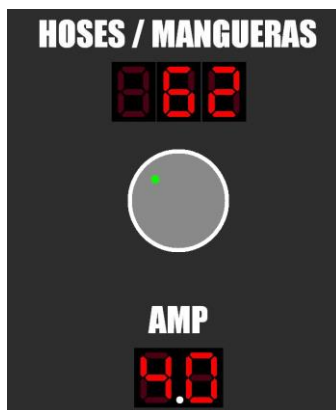

HOSE TEMP OFF

manual control

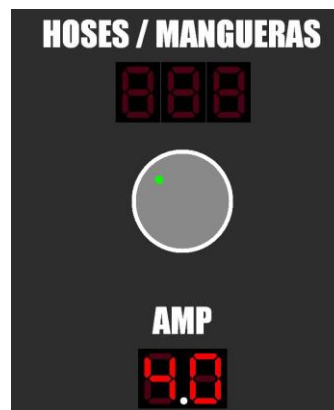

To select the temperature when the unit is working in automatic heating control mode, touch the MODE button, select the desired temperature using the UP/DOWN buttons and touch the MODE button again to confirm the setting. Follow the same procedure to select the amperage. When the unit is operating in automatic control mode, this value should be set to between 4.5 and 5.0 amps.

The temperature setting of the hoses cannot be higher than the temperature setting of the heaters.

In cases where only one automatic temperature control system is working (ISO or POL), the limit temperature value is the higher of the two heater settings.

Maximum temperature settings are 80°C for hoses and 90°C for heaters.



Service manual

The sequence for entering commands is as follows:

- First we set the temperature of the ISO and POL heaters.
- Next, we set the temperature of the ISO hoses.
- Then we set the hose current consumption in amps.
- Finally, we enter the cycle preselector setting.

If the temperature control sensor is not active, the symbol (---) appears on the display and the heating switches off.

The setpoint programmed by the machine operator will be memorized for the next heating start-up.

The versions with a transformer, this can be independent or integrated with the machine. In the first case, the temperature of the hoses is controlled by acting on a potentiometer integrated in the transformer. In the second case, the temperature of the hoses can be controlled directly with the corresponding keyboard on the front panel (if it has TCS) or by programming the current intensity (see point 2 on page 13).

In versions with a independent transformer (optional), the lower pushbutton on the transformer switches the hose heating on and off. This pushbutton incorporates an LED which lights up when the heating is operating; a flashing LED indicates that the heater is on but is not heating up.

Turn the potentiometer clockwise to increase amps, and anti-clockwise if you wish to decrease amps. Adjustment ranges from 0 to 50 amps.

Take the values below as an approximate reference to select the intensity that allows reaching the requested application temperature.

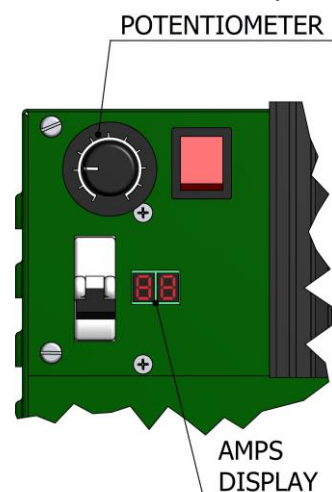

30 A	38° C	100° F
35 A	48° C	118° F
40 A	60° C	140° F
45 A	75° C	167° F
50 A	80° C	176° F

Turn the potentiometer clockwise until the screen shows the required amps for a quick pre-heating.

NOTE: The circuit breaker software of the transformer has a safety system to prevent the hoses from being exposed to high temperatures during long periods of time.

If you have selected a potential over 35 amperes, after 20 minutes, the potential will automatically regulate to 35 amperes.

This potential cannot be set above 35 amperes until the heater is disconnected from the hoses and reconnected.



Service Manual

3. Heaters / Calentadores

This display shows the temperatures in the isocyanate (ISO) and polyol (RESIN) heaters. To enter new temperature settings, press the MODE button, select the desired temperature by pressing the UP/DOWN buttons and press the MODE button again to confirm the selected value.

The lower pushbuttons switch the heater of each product on and off. Each pushbutton incorporates an LED which lights up when the heater is operating; a flashing LED indicates that the heater is on but is not heating up.

The heater will temporarily stop working in the event of excess pressure in either of the heating circuits, and will switch on again once the problem has disappeared.

If the temperature control sensor is not active, the symbol (---) will appear on the display and the heater will switch off.

The hose heating command is not memorized by the unit and therefore it must be activated on every power-up.

4. Mode button

Press this button to modify the different control parameters.

5. Up / Down buttons

Increase or decrease the value of each parameter.

6. Counter / Contador

This display indicates the number of cycles completed, and the number of cycles remaining. The cycle counter is incremental and can be reset to zero by pressing the UP and DOWN buttons simultaneously.

The system offers a certain number of work cycle pre-selects. When the unit completes the pre-selected number of cycles, it stops dispensing product.

To enter the desired number of cycles, press and hold the MODE button until the cycle counter starts flashing, then select the number of cycles by pressing the UP / DOWN buttons as required. Then press the MODE button again to confirm the number of cycles.

When the unit starts, the number of completed cycles is deducted from the number of pre-set cycles. When all the pre-set cycles have completed, the counter displays zero and the unit stops.

The counter display alternately shows (at intervals of two or three seconds) the number of cycles completed (totalizer) and cycles remaining (preselector). The remaining cycles are displayed with a minus sign (-) in front (-XXXXX).

The cycle counter display also shows alerts in the event of malfunction.

You can use the programmable counter cycles as minimum product level in the tanks, setting the counter to 620 cycles and ensuring that the tanks are full. When the counter reaches zero the machine stops in order not to pump air into the system and alerting the lack of product in the tanks. Once the 620 cycles you should reset the counter and fill the tank if you want to reuse as a low level of product tanks.

7. Control / Power button

This button controls the power switch providing electrical power to the heating circuits of the heaters and hoses. When pressed, this button lights up. To disconnect the power supply, press this button again. The power supply automatically cuts out in the event of an alarm for excess temperature in the heaters (alarms 6 and 7) or an alarm for excess intensity in the hose heating (alarm 9).



8. Motor button

This button starts and stops the hydraulic motor. When pressed, this button lights up. To switch off the hydraulic motor, press this button again. The hydraulic motor switches off automatically in the event of hydraulic motor overload (alarm 8). ***The “Motor” function is only available on units with hydraulic drive.***

9. Normal button

Press this button to activate normal operation. When pressed, this button lights up.

10. Retract button

Pressing this button sets the piston of the isocyanate proportioning pump to the retracted position to prevent product residue from crystallizing on the piston. Press the RETRACT button every time you stop the unit. When pressed, this button lights up.

11. Direction indicator lights

These lights indicate the direction of movement of the proportioning pumps (left light for downward movement, and right light upward movement). When there is excess pressure in the system, both these lights go out and alarms 3 and 4 are activated. The NORMAL and RETRACT buttons remain active.



ALARMS

In the event of a malfunction affecting the operation of the unit, it emits an audio signal and shows an alarm code on the COUNTER/CONTADOR display. An alarm cannot be cleared until the problem which caused it has been resolved. After clearing the alarm, press the MODE button.

Procedures for determining the causes of alarms are given below:

1. **Operating voltage under 170V**
 - Check the electrical power connection.
 - Check the transformer's thermomagnetic protection.
2. **Operating voltage above 270V**
 - Check the electrical power connection.
3. **Excess pressure ISO (solenoid valve and heating system cut-out)**
 - Check product pressure.
 - Check LED no. 10 on the printed circuit board: it should be on.
 - Check the safety pressure switch.
4. **Excess pressure POL (solenoid valve and heating system cut-out)**
 - Check product pressure.
 - Check LED no. 11 on the printed circuit board: it should be on.
 - Check the safety pressure switch.
5. **Excess temperature ISO (CONTROL/POWER cut-out)**
 - Check the heater heating system.
 - Check the safety pressure switch connection and allow it to cool down so it can automatically reset.
 - Check LED no. 12 on the printed circuit board: it should be on.
6. **Excess temperature POL (CONTROL/POWER cut-out)**
 - Check the heater heating system.
 - Check the safety pressure switch connection and allow it to cool down so it can automatically reset.
 - Check LED no. 13 on the printed circuit board: it should be on.
7. **Button malfunction (only active when machine is connected to the power supply)**
 - Check the buttons.
8. **Motor malfunction (motor stoppage)**
 - Check the consumption of the hydraulic motor.
 - Check the electrical connections of the hydraulic motor.
 - Check LED no. 15 on the printed circuit board: it should be off.

NOTE: Alarm 8 ("motor malfunction") is only included in units with hydraulic drive.



9. Hose heating system malfunction (CONTROL/POWER cut-out)

- Replace the faulty triac.

000000 Preselected cycles completed (solenoid valve cut-out)

- Press the MODE button to reset the counter.
- Set the cycle selector to zero.



Disconnect the unit from the power supply before opening the electrical console. Electrical maintenance of the machine should only be carried out by a qualified electrician.



PREPARING THE UNIT FOR OPERATION

WARNING! Use suitable protective gear and follow the safety recommendations of the suppliers of the chemical components when preparing or working with the unit.

HI-TECH provides a set of tools and accessories necessary for the assembly of the machine. The set is composed of the following elements:

Item	DESCRIPTION	Qty.
BI-00009	Lithium Grease Tube 50 gr	1x
HT-00001	Magnet holder tool	1x
NR-00030	Parts Manual	1x
NR-00031	Manual Service	1x
NR-00032	Vertical Pumps Manual	1x
OPTIONAL		
MA-00102	12" Hose Connections Protector	2x
EL-00093-01	White Flange 300 x 4.8	3x
HT-00045	Allen key 1/8"	1x
EL-00100-06	Blue Toe Terminal Cable 16 mm ² L=12mm	2x
TN-00242	Threaded rod 1/4"-20 UNC x 14" nylon	2x
EL-00051-00E	ISO TCS Assy (for Units with TCS)	1x
EM-00012	Probe Hose Packaging	1x
EL-00100-06	Blue Toe Terminal Cable 16 mm ² L=12mm	2x
TN-00242	Threaded rod 1/4"-20 UNC x 14" nylon	2x
NR-00033	Recirculation Kit Manual	1x

NOTE: To ensure the correct operation of the unit, the electrical power supply must meet the specifications given on p 7 of this manual and on the unit's rating plate.



Use the proper size of cable according to the voltage, current and maximum power required by the Unit.

The sizing of the cable is calculated for a length of 25m, for longer lengths you must recalculate the appropriate section.

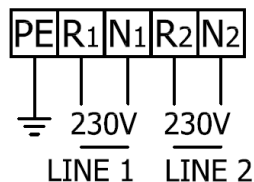

2x 16.0 A @ 1NPE~230V

Cable Section 2,5 mm²

The hoses have been subjected to a vacuum-drying treatment and are delivered with their ends joined to prevent humidity from entering them. Do not separate them until the moment they are to be fitted to the unit.

Proceed as follows to prepare the unit:

- Remove the front protective covering from the pump guides and fill the lube reservoir of the isocyanate pump with DOTP plasticizer.
- Connect the hose for each product to the outlet of its respective heater (the isocyanate hose to the isocyanate heater and the polyol hose to the polyol heater).

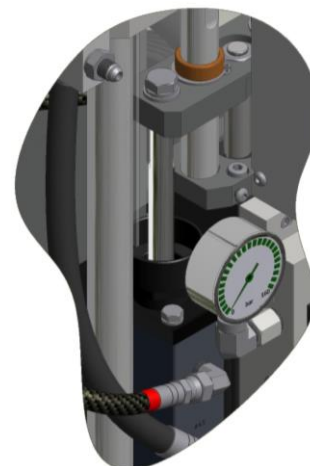

NOTE: The hoses are colour-coded for easy identification: red for isocyanate and blue for polyol. To prevent connection errors, the isocyanate and polyol hose couplers are of different sizes, which makes it impossible to connect a hose to the wrong heater.

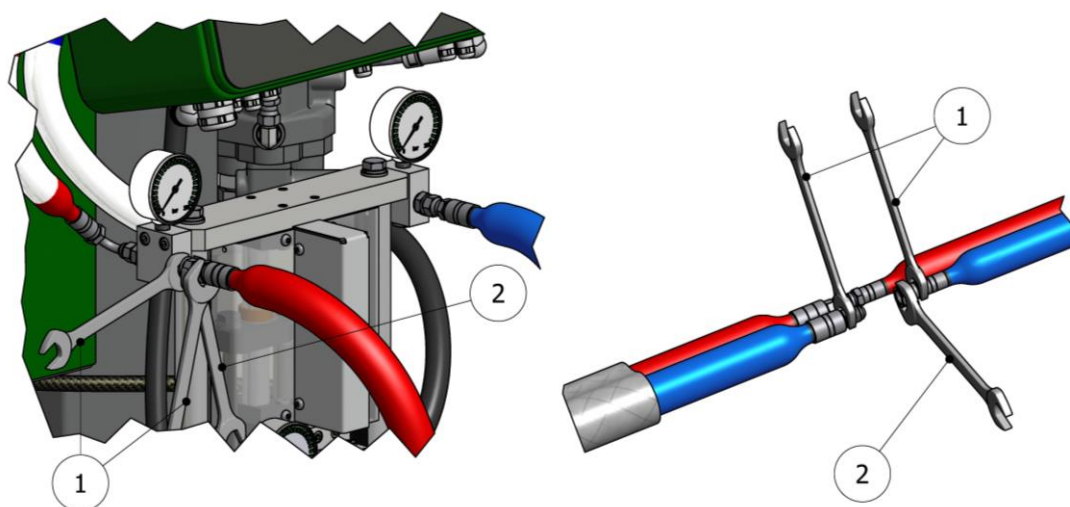

Figure 3. Hose coupling method



Service Manual

WARNING! To join hoses to each other, to the heaters, or to the gun, hold each hose end in place with a spanner (1), and with a third spanner tighten or loosen the coupling nut (2) as required (see Figure 3, pg.20). The tightening torque for these unions must be that indicated according to the procedure on page 29.

- c) Put 22 litres of hydraulic oil in the unit's oil tank. The oil should comply with the characteristics and specifications of standard DIN 51524 sections 1 and 2 (for example ISO VG 46).

NOTE: Do not fill the tank to its maximum capacity (26 litres); the oil level should not exceed 85% of the maximum capacity (22 litres approx.). Use the visor of the oil thermometer to check the oil level, as this should always be completely full (22 litres).

- d) Move the terminal of the hose to the check level (20 mm above the top face of the pump) and check that the oil can be seen at the end of the hose. Add oil if necessary by moving the terminal of the hose to the fill level (70 mm above the top face of the pump), then place the terminal to nipple on the tank.

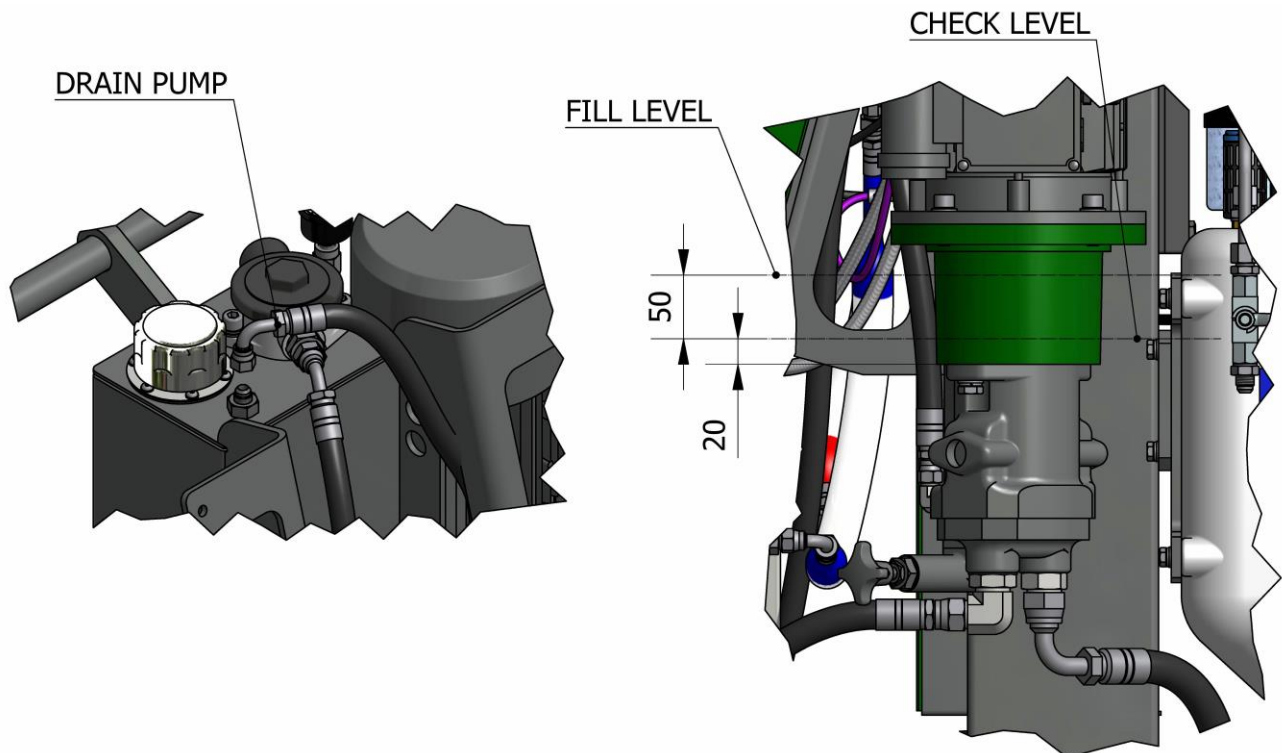



Preparation (units with recirculation hose)

WARNING! Use suitable protective gear and follow the safety recommendations of the suppliers of the chemical components when preparing or working with the unit.

NOTE: To ensure the correct operation of the unit, the electrical power supply must meet the specifications given on p 7 of this manual and on the unit's rating plate.

After following steps, a), b), c) and d) of the preparation procedure (see **p.19**), follow the procedure given below to prepare the unit for recirculation:

- a) Connect the recirculation hose of each product to the recirculation valves located in the respective product tanks (the isocyanate hose to the isocyanate tank valve and the polyol hose to the polyol tank valve).

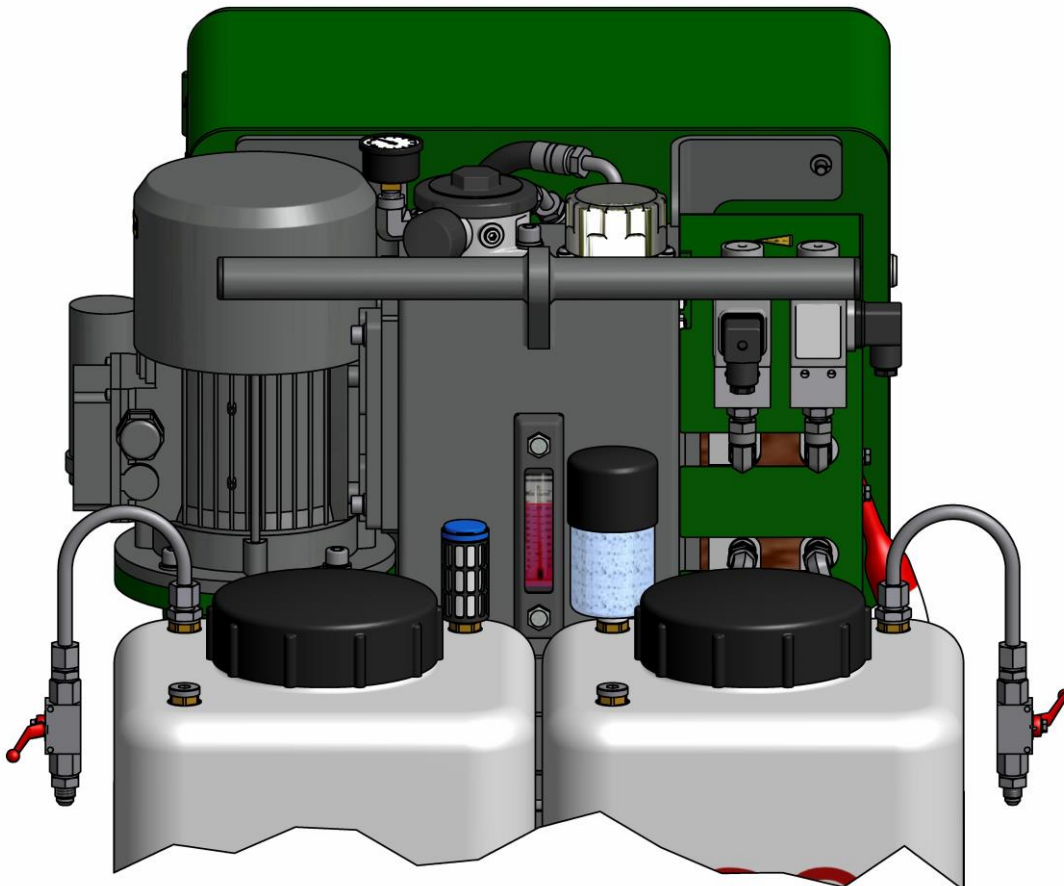



Service Manual

- b) Connect the air hose to the supply connector.
- c) Connect the pressure hoses to the gun couplers, making sure the gun's manual valves are closed (the isocyanate hose to the isocyanate coupler and the polyol hose to the polyol coupler).
- d) Connect the recirculation hoses to the gun couplers (the isocyanate hose to the isocyanate coupler and the polyol hose to the polyol coupler).
- e) Fill the tanks with their respective product.

WARNING!

When handling chemical products, always follow the supplier's safety and storage instructions.

To prevent splash contamination between one tank and the other, open only the cap of the tank being filled with product.

Never swap parts between one tank and the other, and always use the same tank for the same product.

WARNING!

To prevent cross-contamination of products, make sure the tanks are properly closed.

To avoid spillage during transportation of the unit, never fill the tanks completely: always leave about 20% of the tank capacity free (each tank holds 30 litres).

We recommend using small vessels (10-15 litres maximum) for pouring product into the tanks.

Fill the tanks with the amount of product required for each application.

Purge method for hoses with recirculation

Before using the unit, all air pockets and residual oil from in-factory testing must be eliminated. To purge the full circuit, proceed as follows:

- a) Disconnect the isocyanate and polyol recirculation tubes and place them in separate waste recipients.
- b) Open the manual purge valves located under each tank.
- c) Open the manual recirculation valves.
- d) Rotate the power switch to the ON position. The upper pilot light goes on.
- e) Press the CONTROL/POWER button. The LED will light up.
- f) Press the button located under the HOSES/MANGUERAS display. The LED inside the button will light up.

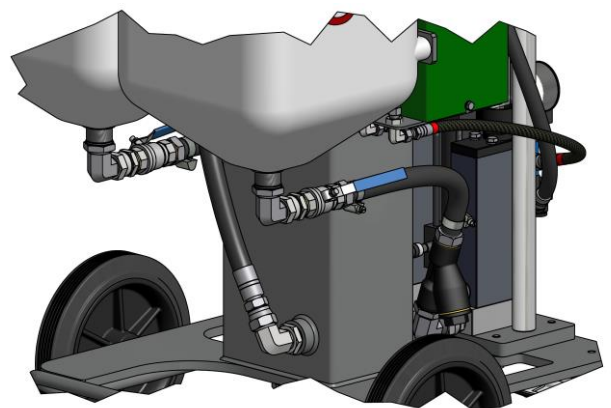



- g) When the products contained in the hoses have reached working temperature, press the ISO and RESIN buttons located under the HEATERS/CALENTADORES display. Both LEDs will light up.

WARNING! *To avoid excess pressure in the heating hoses, wait for the products contained in the hoses to reach the required temperature before starting the hydraulic system.*

- h) Press the MOTOR button. The LED will light up.

Once the above operations have been completed, you now have to check the direction of rotation of the motor. Proceed as follows to make sure the motor is rotating in the clockwise direction:

- i) Rotate the hydraulic pressure regulator in the anticlockwise direction as far as it will go.
j) Rotate the power switch to the ON position. The upper pilot light goes on.
k) Press the CONTROL/POWER button.
l) Position yourself so that you can see the motor fan on the side of the unit. Press the MOTOR button to start the motor, then press it again to stop the motor. Check that the fan blades are turning in the clockwise direction.
m) Rotate the hydraulic pressure regulator in the anticlockwise direction as far as it will go.
n) Rotate the power switch to the ON position. The upper pilot light goes on.
o) Press the CONTROL/POWER button.
p) Press the NORMAL button. The LED will light up. One of the direction indicator lights comes on and the proportioning pumps begin to operate.
q) If necessary, rotate the hydraulic pressure regulator to reach the required pressure, and check the pressure of each proportioning pump on the respective pressure gauges at the unit's outlets.



The hydraulic circuit should be regulated to ensure that the unit's output pressure never exceeds the working pressure of the product hoses fitted to the unit.

- r) Allow the air and oil to escape from the recirculation tubes until there is no more residual oil and the air has stopped gurgling.
s) Close the manual recirculation valves for each product.
t) Remove any product residue from the recirculation tubes and re-connect them to the tanks.
u) Slowly increase the hydraulic pressure to check for any product leakage at any point in the circuit.
v) Rotate the power switch to the OFF position. All displays will switch off.
w) Place the gun in the coupling block.
x) Rotate the power switch to the ON position. The upper pilot light goes on.
y) Press the CONTROL/POWER button. The LED will light up.
z) Press the button located under the HOSES/MANGUERAS display. The LED inside the button will light up.



Service Manual

- aa) When the products contained in the hoses have reached working temperature, press the ISO and RESIN buttons located under the HEATERS/CALENTADORES display. Both LEDs will light up.
- bb) Press the MOTOR button. The LED will light up.
- cc) Press the NORMAL button. The LED will light up. One of the direction indicator lights comes on and the proportioning pumps begin to operate.

The unit is now ready to operate.

Preparation (units with heated hose)

20m heated hose set features one connector for supply voltage and one connector for TCS temperature control.

WARNING! Use suitable protective gear and follow the safety recommendations of the suppliers of the chemical components when preparing or working with the unit.

NOTE: To ensure the correct operation of the unit, the electrical power supply must meet the specifications given on p 7 of this manual and on the unit's rating plate.

After following steps a), b), c) and d) of the preparation procedure (see p.19), follow the procedure given below to prepare the unit to work with heated hoses:

- a) Connect the power cable for the heating of the hoses on the side of the electrical cabinet and the temperature control cable to the TCS connector located on the lower side.

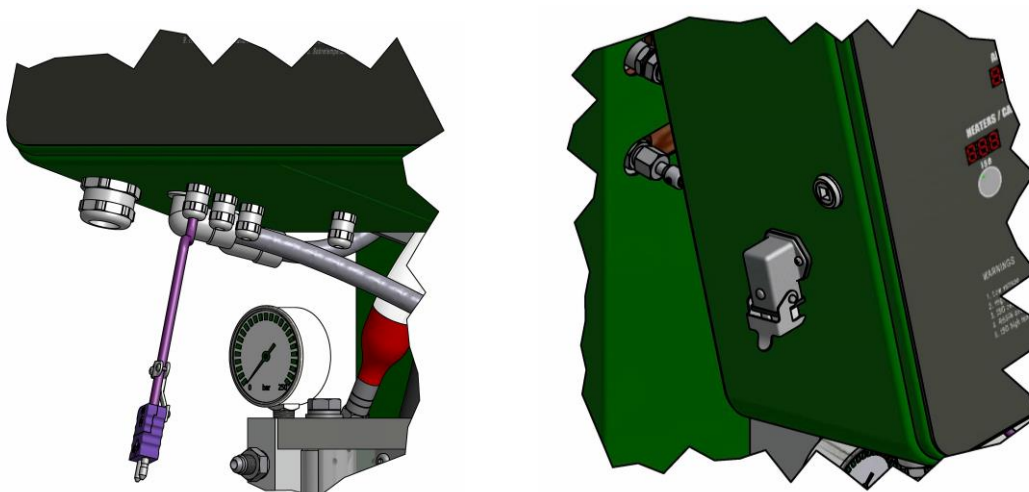

WARNING! To join hoses to each other, to the heaters, or to the gun, hold each hose end in place with a spanner (1), and with a third spanner tighten or loosen the coupling nut (2) as required (see Figure 3 on p. 20). The tightening torque for these unions must be that indicated according to the procedure on page 29.



NOTE: *To prevent product leakage and avoid heating system malfunction, make sure the hoses are correctly connected, electrically and mechanically.*

- b) Connect the air hose to the unit's power socket and to the gun.
- c) Connect the 60 cm whip hose to the gun's coupling block connectors, making sure the manual valves are closed.
- d) Fit the temperature control sensor, with its extension nozzle, between the heated hose and the whip hose connected to the gun. Carefully insert the sensor cable into the heated isocyanate hose.

NOTE: *Once fitted with a temperature control sensor, hoses should be handled with care and should not be folded to excess. When coiling the hoses, make sure the winding radius is at least one metre.*

- e) Insert a contact thermometer under the hose's outer sheath so that the lower part of the thermometer is in contact with the hoses and the upper part projects from the hose's outer sheath. Position the thermometer in such a way that you can see the temperature while spraying. With hoses incorporating a temperature control sensor there is no need to fit a contact thermometer.
- f) Fill the tanks with their respective product.

WARNING!

When handling chemical products, always follow the supplier's safety and storage instructions.

To prevent splash contamination between one tank and the other, open only the cap of the tank being filled with product.

Never swap parts between one tank and the other, and always use the same tank for the same product.

WARNING!

To prevent cross-contamination of products, make sure the tanks are properly closed.

To avoid spillage during transportation of the unit, never fill the tanks completely: always leave about 20% of the tank capacity free (each tank holds 30 litres).

We recommend using small vessels (10-15 litres maximum) for pouring product into the tanks.

Fill the tanks with the amount of product required for each application.

Purge method for heated hoses

Before using the unit, all air pockets and residual oil from in-factory testing must be eliminated. To purge the full circuit, proceed as follows:

- a) Open the manual purge valves located under each tank.
- b) Place the coupling block so that each product drains into a separate recipient and open the manual valves of each product.
- c) Rotate the power switch to the ON position. The upper pilot light goes on.
- d) Press the CONTROL/POWER button. The LED will light up.



Service Manual

- e) Press the button located under the HOSES/MANGUERAS display. The LED inside the button will light up.
- f) When the products contained in the hoses have reached working temperature, press the ISO and RESIN buttons located under the HEATERS/CALENTADORES display. Both LEDs will light up.

WARNING! To avoid excess pressure in the heating hoses, wait for the products contained in the hoses to reach the required temperature before starting the hydraulic system.

- g) Press the MOTOR button. The LED will light up.

Once the above operations have been completed, you now have to check the direction of rotation of the motor. Proceed as follows to make sure the motor is rotating in the clockwise direction:

- h) Rotate the hydraulic pressure regulator in the anticlockwise direction as far as it will go.
- i) Rotate the power switch to the ON position. The upper pilot light goes on.
- j) Press the CONTROL/POWER button.
- k) Position yourself so that you can see the motor fan on the side of the unit. Press the MOTOR button to start the motor, then press it again to stop the motor. Check that the fan blades are turning in the clockwise direction.
- l) Rotate the hydraulic pressure regulator in the anticlockwise direction as far as it will go.
- m) Rotate the power switch to the ON position. The upper pilot light goes on.
- n) Press the CONTROL/POWER button.
- o) Press the MOTOR button. The LED will light up.
- p) Press the NORMAL button. The LED will light up. One of the direction indicator lights comes on and the proportioning pumps begin to operate.
- q) If necessary, rotate the hydraulic pressure regulator to reach the required pressure, and check the pressure of each proportioning pump on the respective pressure gauges at the unit's outlets.



The hydraulic circuit should be regulated to ensure that the unit's output pressure never exceeds the working pressure of the product hoses fitted to the unit.

- r) Open the coupling block manual valves.
- s) Allow the materials to escape via the coupling block until there is no more residual oil and the air has stopped gurgling.
- t) Close the manual valves for each product and remove residual product from the coupling block.
- u) Rotate the power switch to the OFF position. All displays will switch off.
- v) Place the gun in the coupling block.
- w) Rotate the power switch to the ON position. The upper pilot light goes on.
- x) Press the CONTROL/POWER button. The LED will light up.



Service manual

- y) Press the button located under the HOSES/MANGUERAS display. The LED inside the button will light up.
- z) When the products contained in the hoses have reached working temperature, press the ISO and RESIN buttons located under the HEATERS/CALENTADORES display. Both LEDs will light up.
 - aa) Press the MOTOR button. The LED will light up.
 - bb) Press the NORMAL button. The LED will light up. One of the direction indicator lights comes on and the proportioning pumps begin to operate.

The unit is now ready to operate.



METHOD OF THREADED UNION OF THE HOSES

Follow the torques for threaded joints listed in **Table 1** according to thread sizes of hose fittings to ensure their proper assembly.

There is also an alternative procedure to obtain an equivalent torque without using special tools: joint both ends of the hoses to be connected, tighten a swivel nut by hand (without using spanner) until there is resistance on the nut. Fit two spanners (1) on the fixed ends of the hoses and turn the swivel nut with a third spanner (2) as many flats from wrench resistance (FFWR) as indicated in **Table 1**.

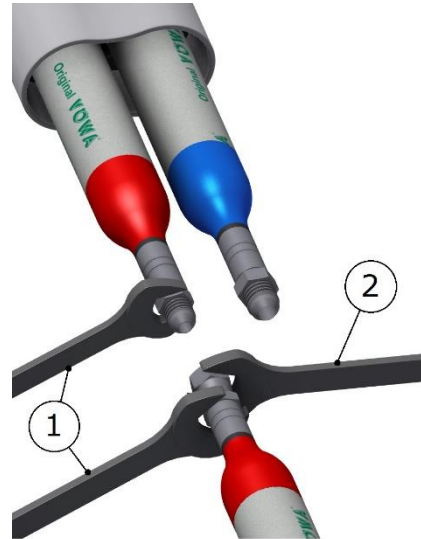
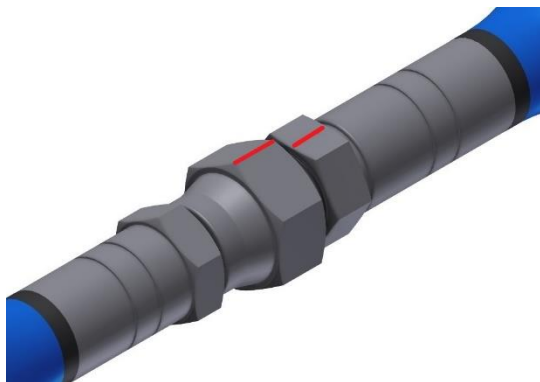

Table 1. Tightening Threaded Joints

THREAD SIZE	TORQUE Nm	FFWR
1/2"-20	23	2 (or 120°)
9/16"-18	30	1-1/2 (or 90°)

NOTE: 1 FFWR corresponds to one complete shear of a flat marked with red between swivel and fitting or else 60°.





POWER-UP PROCEDURE

Follow the recommended procedure, in the sequence given, to power-up the unit:

WARNING! *Do not start the power-up procedure described below until all necessary prior adjustments have been made correctly.*

- a) Check the condition of the DOTP plasticizer contained in the isocyanate pump's lube reservoir. Change the oil if it is discoloured or shows signs of solidification, and tighten the packing nut to make the seal tight.
- b) Make sure the product tanks are full or have the minimum content for application to begin.
- c) Check the product intake filters. Clean them if necessary.
- d) Open the manual purge valves located under each tank.
- e) Open the manual recirculation valves (hoses with recirculation).

NOTE: *Only perform this step if you wish to recirculate the products.*

NOTE: *Recirculation of products enables heater temperature settings to be reached quicker, heating both the hoses and the gun. For more efficient heating during recirculation, fill the tanks with the minimum amount of product necessary for the application.*

WARNING! *The product tanks are made of a plastic material which can withstand a maximum temperature of 80°C. The temperature of the products inside the tanks must never exceed this limit.*

WARNING! *Never recirculate when the tanks are completely full, as this can cause abnormally high pressure in the tanks.*

- f) Check the hydraulic oil level. Add oil if the level is low.
- g) Make sure the products are at the minimum required temperature for their delivery to the unit via the transfer pumps. Contact your supplier for information on the minimum delivery temperature.
- h) Check the product intake filters. Clean them if necessary.
- i) Rotate the power switch to the ON position. The upper pilot light goes on.
- j) Press the CONTROL/POWER button. The LED will light up.
- k) Press the button located under the HOSES/MANGUERAS display. The LED inside the button will light up.
- l) When the products contained in the hoses have reached working temperature, press the ISO and RESIN buttons located under the HEATERS/CALENTADORES display. Both LEDs will light up.



Service Manual

WARNING! To avoid excess pressure in the heating hoses, wait for the products contained in the hoses to reach the required temperature before starting the hydraulic system.

- m) Press the MOTOR button. The LED will light up.
- n) Press the NORMAL button. The LED will light up. One of the direction indicator lights comes on and the proportioning pumps begin to operate.
- o) Rotate the hydraulic pressure regulator to reach the required pressure, and check the pressure of each proportioning pump on the respective pressure gauges at the unit's outlets.



The hydraulic circuit should be regulated to ensure that the unit's output pressure never exceeds the working pressure of the product hoses fitted to the unit.

- p) Set the isocyanate heater temperature.
- q) Set the polyol heater temperature.
- r) Set the hose heating temperature and intensity.

For hoses with recirculation:

- s) Close the recirculation valves if open and open each product's manual valves on the gun. Perform a test spray and check the pressure readings on each product's pressure gauge. If the test spray is satisfactory and the pressure readings remain identical, proceed with application.

Pressure readings should be practically identical and should remain constant. One direction indicator light should remain on and the other off. The light which is on indicates the direction of movement of the pumps.

If the pressures oscillate with each movement, consult the Malfunctions section before continuing.

- t) Connect the air supply to the gun, open the manual valves for each product, perform a test spray and check the readings on the pressure gauges of each product. If the test spray is satisfactory and the pressure readings remain identical, proceed with application.



POWER-DOWN

Follow the recommended procedure, in the sequence given, to power-down the unit when you have finished using it:

- a) Press the RETRACT button. The LED will light up.
- b) Operate the gun, spraying into a waste recipient until the isocyanate proportioning pump is in the retracted position and the spray angle begins to decrease.

WARNING! To prevent product leakage and premature deterioration of the pump's seal rings, do not reduce the pressure to zero. We recommend keeping the system at a minimum pressure of 30 bars to prolong the life of the seal rings.

- c) Press the MOTOR button. The LED will go out.
- d) Press the ISO and RESIN buttons located below the heater temperature display. Both LEDs will go out.
- e) Press the button located under the HOSES/MANGUERAS display. The LED will go out.
- f) Press the CONTROL/POWER button. The LED will go out.
- g) Rotate the power switch to the OFF position. The upper pilot light goes out.
- h) Close the stop valves controlling intake of the products.
- i) Close the manual valves on the coupling block and dismount the gun for carrying out the necessary maintenance.



CLEANING PROCEDURE (HEATED HOSES)

WARNING! *This unit includes parts which reach temperatures likely to cause burns. Do not touch or handle the hot parts of the unit until they have cooled down.*

To avoid possible contamination, all of the unit's circuits (pumps, heaters and hoses) must be cleaned before applications which require a change of components.

Follow the steps given below to clean the unit before changing any of its components:

NOTE: *Save reusable products to suitable recipients, following the instructions of the manufacturer.*

- a) Open the manual purge valves located under each tank.
- b) Place the tubs containing the DOTP cleaning agent near the unit.
- c) Dismount the gun and leave the coupling block joined to the hoses.
- d) Place a recipient below the coupling block to collect the products contained in the tanks and inside the unit.
- e) Rotate the power switch to the ON position.
- f) Open the taps on the coupling block and press the CONTROL/POWER, MOTOR and NORMAL buttons to start the proportioning pumps.
- g) Let the materials drain into their recipients from the coupling block until the tanks are completely empty.
- h) Press the NORMAL, MOTOR and CONTROL/POWER buttons to stop the proportioning pumps. The displays on the temperature regulators will go out.
- i) Rotate the power switch to the OFF position.
- j) Close the manual valves located below each product tank.
- k) Close the taps on the coupling block
- l) Fill the product tanks with DOTP cleaning agent (approx. 5 litres).
- m) Rotate the power switch to the ON position.
- n) Open the manual purge valves located under each tank.
- o) Open the taps on the coupling block and press the CONTROL/POWER, MOTOR and NORMAL buttons to start the proportioning pumps.
- p) Let the DOTP cleaning agent drain into the recipient from the coupling block until the tanks are completely empty.
- q) Press the NORMAL, MOTOR and CONTROL/POWER buttons to stop the proportioning pumps. The displays on the temperature regulators will go out.
- r) Rotate the power switch to the OFF position.
- s) Close the manual valves located below each product tank.
- t) Close the taps on the coupling block.
- u) Proceed as indicated in the instructions for preparing the unit.



CLEANING PROCEDURE (HOSES WITH RECIRCULATION)

WARNING! *This unit includes parts which reach temperatures likely to cause burns. Do not touch or handle the hot parts of the unit until they have cooled down.*

To avoid possible contamination, all of the unit's circuits (pumps, heaters and hoses) must be cleaned before applications which require a change of components.

Follow the steps given below to clean the unit before changing any of its components:

- a) Disconnect the isocyanate and polyol recirculation tubes and place them in separate waste recipients.

NOTE: *Save reusable products to suitable recipients, following the instructions of the manufacturer.*

- b) Open the manual purge valves located under each tank.
- c) Open the manual recirculation valves.
- d) Place the tubs containing the DOTP cleaning agent near the unit.
- e) Dismount the gun and leave the coupling block joined to the hoses.
- f) Put the recirculation hose end in a recipient to collect the products contained in the tanks and inside the unit.
- g) Rotate the power switch to the ON position.
- h) Check that the taps on the coupling block are closed and press the CONTROL/POWER, MOTOR and NORMAL buttons to start the proportioning pumps.
- i) Check that the product pumps are working.
- j) Let the materials drain into the recipient from the recirculation hoses until the tanks are completely empty.
- k) Press the NORMAL, MOTOR and CONTROL/POWER buttons to stop the proportioning pumps. The displays on the temperature regulators will go out.
- l) Rotate the power switch to the OFF position.
- m) Close the manual valves located below each product tank.
- n) Fill the product tanks with DOTP cleaning agent (approx. 5 litres).
- o) Open the manual purge valves located under each tank.
- p) Close the recirculation valves for each product.
- q) Reconnect the recirculation hoses to their respective tanks and re-open the recirculation valves.
- r) Rotate the power switch to the ON position.
- s) Press the CONTROL/POWER, MOTOR and NORMAL buttons to start the proportioning pumps.



Service Manual

- t) Let the unit recirculate for 2-3 minutes to clean the hoses and tanks. For better tank cleaning results, heat the cleaning agent with the heaters.
- u) Press the NORMAL, MOTOR and CONTROL/POWER buttons to stop the proportioning pumps. The displays on the temperature regulators will go out.
- v) Rotate the power switch to the OFF position.
- w) Close the recirculation valves located under each product tank.
- x) Disconnect the recirculation tubes from the isocyanate and polyol tanks and place them in separate waste recipients.
- y) Open the recirculation valves located under each product tank and make sure the taps on the coupling block are closed.
- z) Rotate the power switch to the ON position.
- aa) Press the CONTROL/POWER, MOTOR and NORMAL buttons to start the proportioning pumps.
- bb) Check that the product pumps are working.
- cc) Let the cleaning agent drain from the recirculation tubes until the tanks are empty.
- dd) Press the NORMAL, MOTOR and CONTROL/POWER buttons to stop the proportioning pumps. The displays on the temperature regulators will go out.
- ee) Rotate the power switch to the OFF position.
- ff) Close the manual valves located below each product tank.
- gg) Close the manual recirculation valves.
- hh) Proceed as indicated in the instructions for preparing the unit.



TEMPORARY LAYOFF OF THE UNIT

WARNING! *This unit includes parts which reach temperatures likely to cause burns. Do not touch or handle the hot parts of the unit until they have cooled down.*

When the unit is to be out of service for over FOUR weeks, you must replace the products contained in the unit with DOTP plasticizer.

Follow the steps given below to replace the products with DOTP plasticizing agent:

NOTE: *If the products contained in the unit can be reused, save them to suitable recipients, following the instructions of the supplier.*

- a) Perform the cleaning procedure for hoses with recirculation (see **p.34**) or heated hoses (see **p.33**), as appropriate.
- b) Fill the product tanks with DOTP cleaning agent (approx. 5 litres).
- c) Open the manual purge valves located under each tank.
- d) Make sure the taps on the coupling block (in the case of heated hoses) or the recirculation taps (in the case of hoses with recirculation) are closed.
- e) Rotate the power switch to the ON position.
- f) Press the CONTROL/POWER and MOTOR buttons.
- g) Press the RETRACT button and wait for the proportioning pumps to descend into the retract position.
- h) Press the RETRACT, MOTOR and CONTROL/POWER buttons to stop the proportioning pumps.
- i) Rotate the power switch to the OFF position.
- j) Reduce product pressure by opening the taps on the coupling block (in the case of heated hoses) or the recirculation taps (in the case of recirculation hoses) and then closing them.

To prevent product leakage and the premature wear of pump packing seals, do not reduce pressure to zero. We recommend keeping the system at a minimum pressure of 30 bars to prolong the service life of packing seals.

Proportioning pumps, heaters and hoses should always be filled with DOTP plasticizer when the unit is not in use. **Never leave the unit or its hoses empty of product or DOTP plasticizer.**

NOTE: *Never use liquids not recommended or not approved by HI-TECH. Never use approved liquids that have been contaminated with water or ISO/POL. If you are not sure in the quality of the liquid you are going to use we strongly recommend that you check the machine 2-3 times every 2 weeks after you have filled it by recirculating through heated hoses (see p.34) and/or hoses with recirculation (see p.33) with fresh plasticizer unless you make sure the liquid that comes out is completely pure and clean.*



MALFUNCTION

The **novaG - I** unit has been designed and built to operate in severe working conditions. It will work with a high degree of reliability on condition that it is used and maintained correctly. This section contains information on the possible causes of malfunctions in the unit. Most problems with the unit can be detected and resolved using the information provided in this section. Please refer to this information before requesting technical assistance from your authorized dealer or HI-TECH technical services. Feel free to contact the technical assistance service of HI-TECH Spray Equipment, S.A. at any time. Our team of qualified technicians is on hand to help and advise you when necessary.

NOTE: *Repairs by unqualified personnel or the use of non-original replacement parts can damage the unit and endanger the safety of the operator.*



To avoid bodily damage caused by the incorrect handling of the substances and solvents used in the spraying process, read carefully the safety information provided by suppliers.

Dispose of waste as required by applicable legislation.



Disconnect the unit from the power supply before opening the electrical console.

Electrical maintenance should only be carried out by a qualified electrician.



To avoid exposure to pressurized fluids, do not release any connectors or perform maintenance work on parts subjected to pressure until the pressure has been completely eliminated.

Use suitable protection when using or performing maintenance on the unit, or when in its vicinity. This protection includes, but is not limited to, the use of masks, protective goggles, gloves, safety footwear and safety clothing.



This unit includes parts which reach temperatures likely to cause burns. Do not touch or handle the hot parts of the unit until they have cooled down.



To avoid the risk of crushing or amputation, only use this unit when its moving parts are fitted with correctly installed safety guards. Make sure all safety guards are correctly mounted after completing repair or maintenance work.



Heaters

WARNING! Before attempting to fix any kind of malfunction, make sure that no buttons are lit on the electrical panel, that the power switch is in the OFF position and that the unit is disconnected from the power supply. Never open the electrical console when the unit is connected to the power supply. Heaters can reach high temperatures. Always wait until they have cooled down before handling them.

NOTE: The thermostat is a safety device which is in contact with the heater. If the temperature exceeds 120°C (248°F) the thermostat will cut off the power supply to the temperature regulator. The thermostat will not start working again until the temperature of the heater falls below 120°C (248°F).

If the temperature of either heater (isocyanate or polyol) exceeds 90°C (194°F) an alarm will activate and the corresponding number will appear on the control panel (5 for isocyanate and 6 for polyol).

Follow the procedure below, in the sequence given, to rectify the problem and avoid expensive repairs. Check that all automatic switches are in the correct working position before proceeding to locate faults.

TERMOSTATOS
DE SEGURIDAD

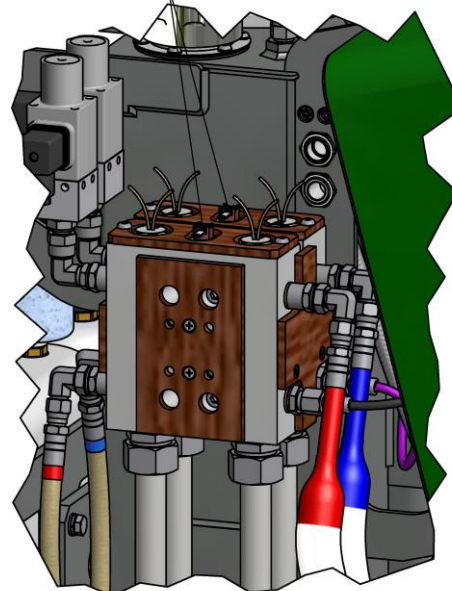

PROBLEM

The heater does not heat up, although the LED in the heater button is lit.

The symbol (---) appears on the heater display.

SOLUTIONS

1-2-3

4

SOLUTIONS

1. Heating elements

Each heater contains two 900 W heating elements, connected in parallel and delivering a total heating power of 1800 W (novaG - I model). If a heater fails to reach the required temperature after two or three minutes, it's possible that one of its two elements is faulty.

To check the elements, proceed as follows:

With the power switch in the OFF position, use a tester to check the total resistance of the heater, which should be 30 Ohms. A higher reading may indicate that one or more elements are faulty.



Service Manual

Disconnect the elements and check that the individual resistance of each element is 60 Ohms. Extreme environmental conditions may affect the operation of the heaters, preventing them from reaching the required temperature. In such circumstances, try moving the unit to a warmer location or use an auxiliary heating system.

2. Static relay

If the above checks have not revealed any problems, check the static relay.

3. Automatic switch

The automatic switch protects the heating elements against voltage surges. With the power disconnected, open the control panel and make sure the switch is primed (see circuit diagram). If not, prime it.

4. Temperature sensor

Temperature sensor malfunctions are automatically displayed on the control panel. In the event of a malfunction, replace the sensor, being careful not to damage it during installation. The sensor should be in contact with the element.

Hose heating

WARNING! Before attempting to fix any kind of malfunction, make sure that no buttons are lit on the electrical panel, that the power switch is in the OFF position and that the unit is disconnected from the power supply. Never open the electrical console when the unit is connected to the power supply. Hoses can reach high temperatures. Always wait until they have cooled down before handling them.

Follow the procedure below, in the sequence given, to rectify the problem and avoid expensive repairs. Check that all automatic switches are in the correct working position before proceeding to locate faults.

PROBLEMS

SOLUTIONS

The hose heats up but does not reach the programmed temperature.	1-2-8
The hose does not heat up but the LED is lit.	3-4-5-6
The symbol (---) appears on the hose display.	7
The automatic switch trips.	3



SOLUTIONS

1. Hoses without product or air pockets in hoses

Purge the air from the hoses.

2. The ISO heater is not delivering the required temperature

See the section on heater problems.

3. Hose connector

Check the hose connector's electrical connection on the left hand side of the console.

4. Heating element disconnected

Check that the resistance reading in the hose is $33\Omega \pm 2\Omega$

5. F4 automatic switch

Protects against current spikes in the hose circuit. This switch is located inside the control panel. Check that it is set to the ON position. If the switch is not working properly, replace it with one of equal amperage.

WARNING! Replacing the automatic switch with another of different characteristics can damage the unit and endanger the safety of the operator.

6. Triac

If the other checks have not revealed any problems, check the triac. Replace the triac if it is not working properly.

7. TCS temperature control sensor

Temperature sensor malfunctions are automatically displayed on the control panel. To determine whether the fault is caused by the sensor itself or by a defective electrical connection, perform the following check: unscrew the temperature control sensor's electrical connector from the end of the hose, and without removing any other connection connect it directly to the unit's electrical outlet. If the control function reappears, check the electrical connections of the temperature control sensors at both ends of the hose, and if necessary replace the temperature control sensors.

8. Adjusting the hose heating temperature

The purpose of the hose heating system is to keep the temperature of the products in the hose at the same temperature as they left the heaters. Therefore, the maximum hose temperature setting (80°C) is the same as the maximum setting on the heaters display.



Proportioning pumps

WARNING! Before attempting to fix any kind of malfunction, make sure the power switch is in the OFF position and that the unit is disconnected from the power supply. Never open the electrical console when the unit is connected to the power supply. Proportioning pumps work under pressure. Do not release any connection or perform repair or maintenance work on components subjected to pressure until all pressures have been completely eliminated.

PROBLEMS	SOLUTIONS
The pumps lose pressure when the unit is stopped.	1
The pressure readings in the proportioning pumps are different.	1-2-3
There is cavitation in the proportioning pump.	1-2-3
The proportioning pumps do not reverse direction.	4
The proportioning pumps do not move.	4
The movement of the proportioning pumps is erratic.	4-5

SOLUTIONS

1. Pressure loss in ball valves

Observe the pressure gauges to identify which pump is losing pressure. To determine which ball valve is faulty, check in which direction of movement the pump loses pressure. If pressure is lost in the upward stroke, check the discharge (upper) ball valve. If pressure is lost on the downward stroke, check the intake (lower) ball valve.

Proceed as follows to check the ball valves:

- Disconnect the unit from the power supply and shut the stop valves controlling product intake underneath the tanks.
- Depressurize the proportioning pump and dismount the faulty ball valve.
- Pressure loss in ball valves is usually caused by foreign particles which prevent the ball from coupling perfectly with the seat in the upper part of the closing bushing. Clean the ball and the surface of the bushing seat and check there are no nicks, marks or scratches on the bushing or the ball. If cleaning does not resolve the problem, or if any defects are detected, replace the bushing and the ball.

2. Pressure reading imbalances

Pressure reading imbalances occur when an obstruction in the hose or gun prevents one of the spray components from exiting the nozzle during spraying, or when a problem in the pumping system prevents one of the components from reaching the gun in the required quantities.

Identifying which component is causing the imbalance is relatively easy, as the component chemical products used in the polyurethane foam spray system are of different colours. By observing the colour of the component coming out of the gun you can determine which component is missing.



To ascertain whether the pressure imbalance is caused by an obstruction or by a problem in the pumping system, operate the spray gun and check the reading on the pressure gauge of the missing component. Compare this reading with the pressure indicated on the other component's pressure gauge: if the pressure of the missing component is higher, the pressure imbalance is caused by an obstruction; if it is lower, the imbalance is due to a problem in the pumping system.

3. Cavitation

Cavitation occurs when the proportioning pump requires a greater volume of material than the feed system is supplying, giving rise to the formation of voids in the proportioning pump. There are three possible causes of cavitation:

- a) High viscosity. Polyurethane foam spray systems normally require a minimum transfer temperature of 12°C: at lower temperatures, the viscosity of the component products increases and it is more difficult to pump them. When ambient conditions do not allow the component products to be kept at the minimum temperature of 12°C, auxiliary heating equipment must be used to keep the component products at the minimum required transfer temperature.
- b) The product intake filter is clogged (see Maintenance).
- c) The intake ball valve is leaking as a result of wear or defects in the ball or the closing surface of the bushing, which causes some of the material to return to the tank. Therefore the volume of material delivered by the proportioning pump in the discharge cycle is lower than required, giving rise to an incorrect product ratio.

4. Fault in the direction change sensor

The metering pump system has a plate that activates the reversing switches to carry out the change of direction. The most common cause of the fault is the entry of a foreign body preventing the plate from making contact with the micros.

A fault in the movement of the directional valve will cause the activation plate to pass the micro and not make the change of direction. Proceed as follows to solve this problem:

- a. Determine the direction in which the plate must move; this depends on which micro has been passed.
- b. Locate the slide for the manual override of the directional valve located on the front of the hydraulic cylinder. Act on the side to which you want the activation plate to move.
- c. Turn the general switch ON, press the POWER CONTROL key and the MOTOR key. With the manual valves of the coupling block open, point the gun at a waste container.
- d. Press the manual slide of the directional valve and hold it until the activation plate is centred between the two run end micros.
- e. If when pressing the slide, it moves freely, the excess run is due to an electrical problem. Press the MOTOR key and the NORMAL key; press the run end micros and check whether the reels are changed and the direction indicator lights: if the reels are not changed or the direction indicator lights fail to come on, there is an electrical problem in the run end micro or in the reels of the directional valve.

5. Tank empty

As there is no way of visually checking the level of product in the tanks during the normal operation of the unit, there is a risk that air will enter the circuit if the level in one tank is too low. This will cause the pumping system to malfunction.

If this problem occurs, purge the air from the circuit as described in the corresponding section on **p.23** (hoses with recirculation) or **p.26** (heated hoses).



Hydraulic drive

WARNING! Before attempting to fix any kind of malfunction, make sure that no lights are lit on the control panel, the power switch is set to the OFF position, and the unit is disconnected from the power supply. Never open the electrical console when the unit is connected to the power supply. The hydraulic motor operates under pressure. Do not release any connection or perform repair or maintenance work on components subjected to pressure until all pressures have been completely eliminated.

Follow the procedure below, in the sequence given, to rectify the problem and avoid expensive repairs. Check that all automatic switches are in the correct working position before proceeding to locate faults.

PROBLEMS

SOLUTIONS

The electric motor does not start, or stops during operation.	1
The hydraulic pump delivers no pressure.	2
Little or no pressure, with chirps.	2-3

SOLUTIONS

1. Automatic switch

The electric motor is protected by an automatic safety switch which trips when too much current is delivered to the motor. Disconnect the unit from the power supply and allow the motor to cool down. Open the control panel and re-prime the automatic switch. The motor should now work normally. If too much current is being delivered to the motor it is important to identify why this is happening, for in the event of failure by the automatic switch the electric motor may be damaged by overheating.

2. Little or no pressure

The most likely cause of lack of pressure is that the hydraulic pump is not delivering enough pressure due to mis-priming, caused by a lack of oil or a clogged intake filter. Check these points to ensure correct operation.

3. Noise

A chirping noise is a common symptom of cavitation. This noise is normal upon power-up and normally disappears after about thirty seconds.

If the chirping continues, stop the unit to protect the hydraulic pump and check that the hose couplings are properly tightened and that the pump is correctly primed. Remove the pump drain coupler and fill the pump if necessary.

Another cause of pump noise is excessive temperature of the hydraulic oil. Make sure the oil is being delivered in the correct quantity, and if necessary improve ventilation to allow greater dissipation of heat from the hydraulic tank.



MAINTENANCE

To obtain optimum performance from the **novaG - I** unit you must perform certain maintenance operations on a daily or regular basis.



To avoid bodily damage caused by the incorrect handling of the substances and solvents used with this unit, read carefully the safety information provided by their suppliers.

Dispose of waste as required by applicable legislation.



Disconnect the unit from the power supply before opening the electrical console.

Electrical maintenance should only be carried out by a qualified electrician.



To avoid exposure to pressurized fluids, do not release any connectors or perform maintenance work on parts subjected to pressure until the pressure has been completely eliminated.

Use suitable protection when using or performing maintenance on the unit, or when in its vicinity. This protection includes, but is not limited to, the use of masks, protective goggles, gloves, safety footwear and safety clothing.



This unit includes parts which reach temperatures likely to cause burns. Do not touch or handle the hot parts of the unit until they have cooled down.



To avoid the risk of crushing or amputation, only use this unit when its moving parts are fitted with correctly installed safety guards. Make sure all safety guards are correctly mounted after completing repair or maintenance work.



Heaters

WARNING! Before proceeding to any kind of maintenance work, make sure the power switch is in the OFF position and that the unit is disconnected from the power supply. Never open the electrical console when the unit is connected to the power supply. Heaters can reach high temperatures. Always wait until they have cooled down before handling them.

1. Heating elements

To replace a defective heating element, proceed as follows:

- a) Depressurize the unit, disconnect it from the power supply and remove the heater cap.
- b) Disconnect the element from the terminal block using the appropriate tool, loosen the element and remove it from its housing. The element should be smooth and shiny in appearance. If it is blackened or shows accretions of material, replace it.
- c) Check the new element with a tester: the resistance reading should be 60 Ohms.
- d) Apply PTFE or thread-locking compound and screw the element into place in its housing.
- e) Re-connect the cables in the terminal block, make sure the connection is parallel and replace the heater cap.

NOTE: If the element to be replaced is the element in contact with the temperature sensor, first remove the sensor.

2. Temperature sensor

The temperature sensor is secured to the hose coupling with a ferrule and a torque nut. Once inserted in its housing, the ferrule forms part of the sensor and may not be moved out of position. Check that the sensor has been correctly inserted before securing it in place with the torque nut.

- a) Depressurize the unit and disconnect it from the power supply. Check that the body of the coupler inserted in the heater is correctly tightened to prevent leaks.
- b) Fit the heating element.
- c) Fit the torque nut and ferrule to the sensor and insert the sensor into the body of the connector until it touches the heating element. Make sure the spring inside the heater is not impeding contact between the sensor and the element.
- d) Secure the sensor and tighten the locking nut.



Proportioning pumps

WARNING! Before proceeding with maintenance works, make sure that all push buttons are switched off, the general switch is in the off position, and the Unit is unplugged from the power supply. Never handle the control panel interior while the Unit is plugged into the electricity grid. Dosing pumps are components that work under pressure, do not open any connections or perform any repair or maintenance work on components submitted to pressure until all pressures have been completely released.

When the pump works properly, it is not uncommon for a small amount of resin to filter through the joints and reach the visible part of the pump axis. Periodically inspect the axis and clean the residue when dosing pumps are stationary and the machine is switched off.

Disassemble and clean the dosing pumps annually, despite no obvious signs of leaks. Use this time to completely replace the joints and bearings given that, if you reassemble an element that does not seem damaged, it can cause premature wear in the remaining components (the NR-00032 Components Manual includes the joint kits that correspond to each pump model and size). Pump distribution bases must also be inspected, checking that the ball valves show no signs of wear, dents or marks that affect the pump's proper operation.

Perform a daily inspection of the Isocyanate pump lubrication bowl and check the condition of the DOTP plasticiser oil it contains. Replace the oil when you observe colour changes or when it shows signs of solidification. If this circumstance persists, replace the isocyanate pump joints using the corresponding kit.

In cases where the machine is submitted to large workloads or special work conditions, disassemble, clean and replace the dosing pump joints every six months.

Inspect rods, pistons and inside the sleeves for marks or scratches that may cause leaks or premature damage to the joints.

Only qualified personnel will be authorised to replace dosing pump joints, since they have the required expertise to that effect.

To assemble the pump, there are specific tools that prevent damage to the seal lips of both the piston and the cylinder head.



Service Manual

First, assemble the rod set with the piston and all its components. Ensure that the piston seal lips are facing upwards.

Insert the assembled piston set inside the sleeve with the specific tool (1) (see **Table 2** on page.48)

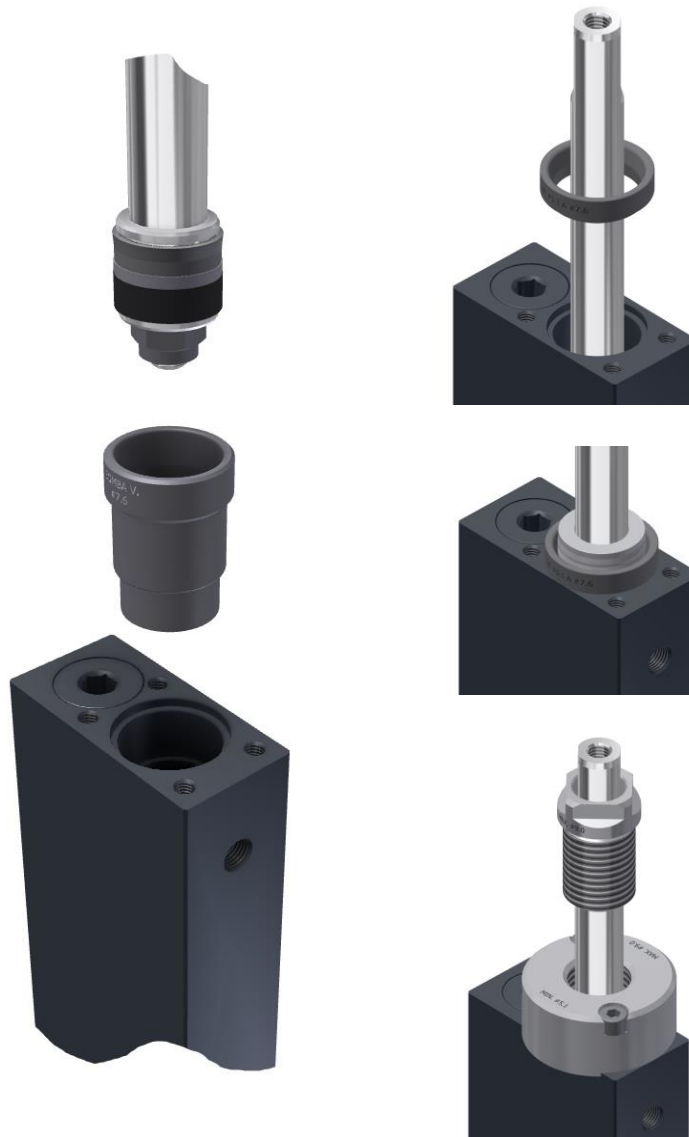

Once you have inserted the piston into the sleeve, you must assemble the cylinder head seal. First place the seal funnel tool (2).





Next, place the cylinder head seal with the lips facing downwards.

Subsequently, you must place and fasten the tool (3) to the sleeve and insert the plunger (4) inside the rod. Screw as far as it will go.

Remove all the tools and finish the pump assembly by placing the guide with its joint, and fastening the piston and the nut with the bowl.



Table 2. List of Tools

	Tool (1)	Tool (2)	Tool (3)	Tool (4)
SIZE				
#4.5	HT-00034	HT-00116	HT-00119	HT-00121
#7.6	HT-00031	HT-00117	HT-00120	HT-00122

Note: These tools are not supplied with the machine, they are optional upon request.



Product intake filters

Filter bodies are fitted with an inner mesh which prevents solid particles from entering the unit and potentially interfering with the operation of the ball valves when the product is taken into the unit. Filters should be inspected and cleaned daily as part of the power-up routine. Replace the inner mesh if necessary.

Isocyanate is a product which crystallizes under the action of ambient humidity or freezing. To minimize the risk of contaminating the isocyanate filter, make sure the product is properly stored and decanted and the operating procedures are followed.

NOTE: *The isocyanate intake filter should be cleaned every day before starting the unit. Do not clean the filter after stopping the unit. To reduce the risk of absorption of humidity and the possibility of contamination by reaction with the cleaning solvent, begin spraying immediately after cleaning the filter.*

To check the product intake filters, proceed as follows:

- a) Disconnect the unit from the power supply and close the tap valve regulating the intake of the product into the filter to be checked.
- b) Place a suitable recipient underneath the filter to collect the product that comes out. Carefully loosen the filter cap to allow the product to drain into the recipient. Unscrew the cap completely.
- c) Remove the gasket, the spring and the mesh and clean all components with the solvent used for cleaning the gun. Dry the components and check there are no obstructions in the mesh. All mesh orifices should be completely clear. Replace the mesh if over 10% of its surface area is clogged.
- d) Put the mesh, the spring and the gasket back in place. Screw the cap in place.
- e) Open the valve tap regulating the intake of product into the filter, check there are no leaks and proceed with normal operations.



Isocyanate pump lubrication system

Inspect the isocyanate pump lube reservoir every day and check the condition of the DOTP plasticizer oil it contains. Replace the oil if it is discoloured or exhibits signs of solidification.

DOTP oil solidifies as a consequence of moisture absorption. The frequency of oil changes depends on the working conditions.

Discolouration of the oil is due to the thin film of isocyanate which is deposited on the pump piston when the pump is operating. The plasticizing oil needs to be changed less frequently if the seal rings and gaskets are in good condition.

To replace the plasticizing oil in the pump, proceed as follows:

- a) Operate the spray gun until the isocyanate proportioning pump is at the highest point on its upward stroke. Rotate the power switch to the OFF position.
- b) Disconnect the unit from the power supply.
- c) Remove the protective panels from the pump guides.
- d) Remove the DOTP oil contained in the chamber, then clean the chamber and the pump piston to eliminate any residue of contaminated oil or crystallized accumulations. Use a wooden or plastic implement to clean the piston. Fill the chamber with new DOTP plasticizing oil.



Hydraulic drive

WARNING! Before proceeding to any kind of maintenance work, make sure all lights on the control panel are off, the power switch is in the OFF position, and the unit is disconnected from the power supply. Never open the electrical console when the unit is connected to the power supply. The hydraulic motor operates under pressure. Do not release any connection or perform repair or maintenance work on components subjected to pressure until all pressures have been completely eliminated.

The hydraulic motor should be serviced every year. To do this, proceed as follows:

- a) Depressurize the unit and disconnect it from the power supply. Clean the cap of the hydraulic tank to prevent extraneous matter from falling into the tank during removal of the hydraulic components.
- b) Dismount and replace the tank's return filter.
- c) Inspect the bottom of the tank through the filter housing to check for the presence of sediment. If sediment is present, empty the tank completely through the purge hole located on its side.

WARNING! Do not mislay the purge hole cap or gasket! Without either of these components you will be unable to refill the tank.

Clean the interior of the pump intake and drain tubes located inside the tank.

Clean the bottom of the tank, eliminating all sediment.

- d) Place the return filter in its operating position.
- e) If the tank has been emptied, or if it needs more oil, fill it up as required.

WARNING! Bear in mind the recommendations on oil (see p.22).

- f) Check that the hydraulic pump is full of oil and make sure coupler connections are tight enough for normal operation.



CONTENTS

Warranty	2
Safety and handling	3
Characteristics	6
Principal heating system	6
Hose heating system	6
Proportioning pumps	6
Technical specifications	7
Electrical	7
Mechanical	7
Acoustic	7
Overview	8
Control panel	12
Alarms	17
Preparing the unit for operation	19
Preparation (units with recirculation hose)	22
Purge method for hoses with recirculation	23
Preparation (units with heated hose)	25
Purge method for heated hoses	26
Method of threaded union of the hoses	29
Power-up procedure	30
Power-down	32
Cleaning procedure (heated hoses)	33
Cleaning procedure (hoses with recirculation)	34
Temporary Layoff of the unit	36
Malfunction	37
Heaters	38
Hose heating	39
Proportioning pumps	41
Hydraulic drive	43
Maintenance	44
Heaters	45
Proportioning pumps	46
Product intake filters	49



Service Manual

Isocyanate pump lubrication system _____	50
Hydraulic drive _____	51
Contents _____	52
List of illustrations _____	53
List of Tables _____	53

LIST OF ILLUSTRATIONS

Figure 1. General view _____	8
Figure 2. Control panel _____	12
Figure 3. Hose coupling method _____	20

LIST OF TABLES

Table 1. Tightening Threaded Joints _____	29
Table 2. List of Tools _____	48